

DTC	B0103/12	Short in D Squib Circuit (to B+)
------------	-----------------	---

CIRCUIT DESCRIPTION

The D squib circuit consists of the airbag sensor assembly, spiral cable and steering wheel pad. It causes the SRS to deploy when the SRS deployment conditions are satisfied.

For details of the function of each component, see OPERATION on page RS-3.

DTC B0103/12 is recorded when a B+ short is detected in the D squib circuit.

DTC No.	DTC Detecting Condition	Trouble Area
B0103/12	<ul style="list-style-type: none"> • Short circuit in D squib wire harness (to B+) • D squib malfunction • Spiral cable malfunction • Airbag sensor assembly malfunction 	<ul style="list-style-type: none"> • Steering wheel pad (D squib) • Spiral cable • Airbag sensor assembly • Wire harness

WIRING DIAGRAM

See page DI-15.

INSPECTION PROCEDURE

1	Prepare for inspection (See step 1 on page DI-82).
---	--

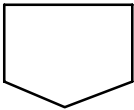

2	Check D squib circuit.
---	------------------------

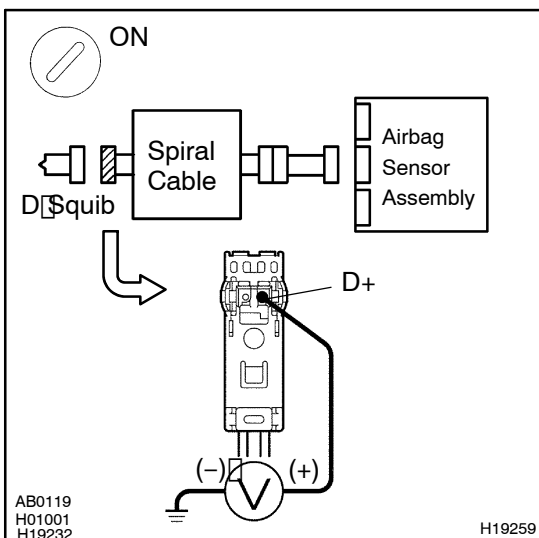

PREPARATION:

Deactivate the LEXUS iLXUS link system (See page DI-1).

CHECK:

- Turn the ignition switch to ON.
- For the orange connector (on the spiral cable side) between the spiral cable and the steering wheel pad, measure the voltage between D+ and body ground.

OK:

Voltage: 0 V

NG	Go to step 5.
-----------	---------------



OK

3 Check airbag sensor assembly.

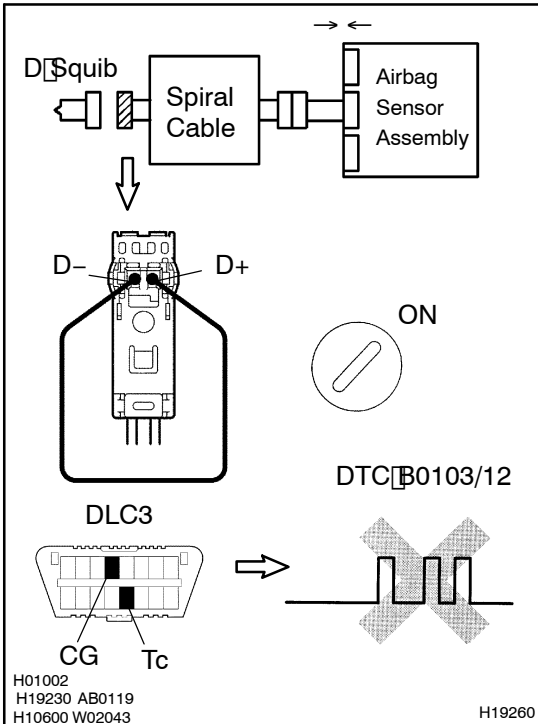

PREPARATION:

- Connect the connector to the airbag sensor assembly.
- Using a service wire, connect D+ and D- of the orange connector (on the spiral cable side) between the spiral cable and the steering wheel pad.
- Connect negative (-) terminal cable to the battery, and wait at least for 2 seconds.

CHECK:

- Turn the ignition switch to ON, and wait at least for 20 seconds.
- Clear the DTC stored in memory (See step 5 on page DI-1)
- Turn the ignition switch to LOCK, and wait at least for 20 seconds.
- Turn the ignition switch to ON, and wait at least for 20 seconds.
- Check the DTC (See page DI-1)

OK:

DTC B0103/12 is not output.

HINT:

Codes other than code B0103/12 may be output at this time, but they are not relevant to this check.

NG

Replace airbag sensor assembly.

OK

4 Check D Squib.

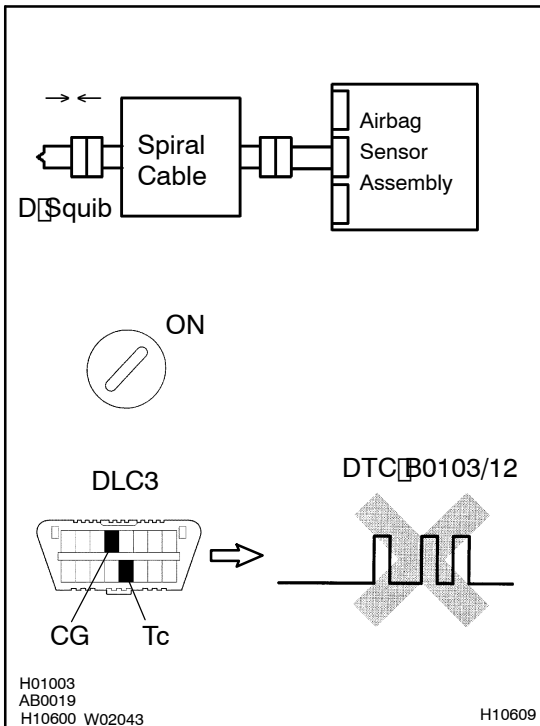

PREPARATION:

- Turn the ignition switch to LOCK.
- Disconnect the negative (-) terminal cable from the battery, and wait at least for 90 seconds.
- Connect the steering wheel pad connector.
- Connect the negative (-) terminal cable to the battery, and wait at least for 2 seconds.

CHECK:

- Turn the ignition switch to ON, and wait at least for 20 seconds.
- Clear the DTC stored in memory (See step 5 on page DI-1)
- Turn the ignition switch to LOCK, and wait at least for 20 seconds.
- Turn the ignition switch to ON, and wait at least for 20 seconds.
- Check the DTC (See page DI-1)

OK:

DTC B0103/12 is not output.

HINT:

Codes other than code B0103/12 may be output at this time, but they are not relevant to this check.

NG

Replace steering wheel pad.

OK

From the results of the above inspection, the malfunctioning part can now be considered normal. To make sure of this, use the simulation method to check. If the malfunctioning part can not be detected by the simulation method, replace all SRS components including the wire harness.

5 Check spiral cable.

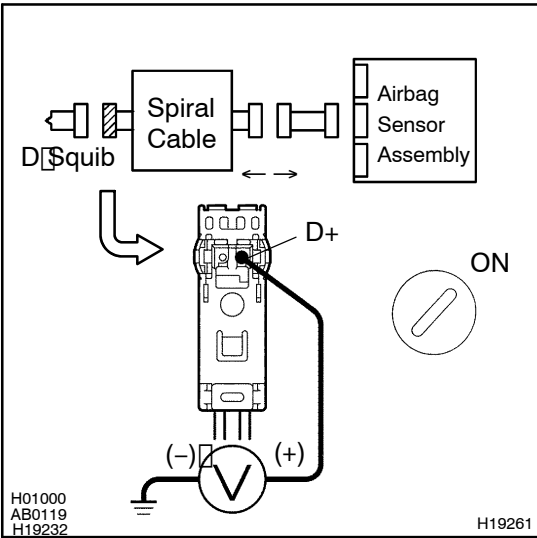

PREPARATION:

- (a) Turn the ignition switch to LOCK.
- (b) Disconnect the connector between the airbag sensor assembly and the spiral cable.
- (c) Deactivate the LEXUS Link system (See page DI-1).

CHECK:

- (a) Turn the ignition switch to ON.
- (b) For the orange connector (on the spiral cable side) between the spiral cable and the steering wheel pad, measure the voltage between D+ and body ground.

OK:

Voltage: 0 V

NG Replace spiral cable.

OK

6 Check harness between airbag sensor assembly and spiral cable.

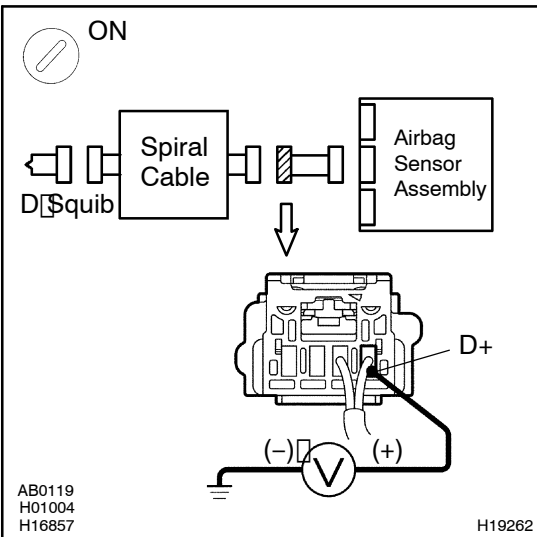

PREPARATION:

Deactivate the LEXUS Link system (See page DI-1).

CHECK:

- (a) Turn the ignition switch to ON.
- (b) For the connector (on the spiral cable side) between the spiral cable and airbag sensor assembly, measure the voltage between D+ and body ground.

OK:

Voltage: 0 V

NG Repair or replace harness between airbag sensor assembly and spiral cable.

OK

From the results of the above inspection, the malfunctioning part can now be considered normal. To make sure of this, use the simulation method to check. If the malfunctioning part can not be detected by the simulation method, replace all SRS components including the wire harness.