

REMOVAL

1. REMOVE V-BANK COVER
2. REMOVE INTAKE AIR CONNECTOR
3. REMOVE FUEL PRESSURE PULSATION DAMPERS
(See page FI-28)
4. DISCONNECT VVT SENSOR CONNECTORS
5. REMOVE V-BANK COVER BRACKETS
6. REMOVE VSV FOR EVAP

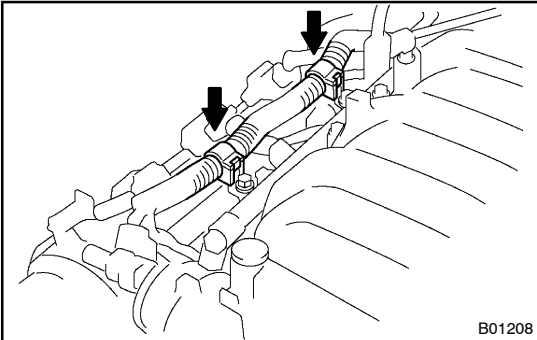

B01208

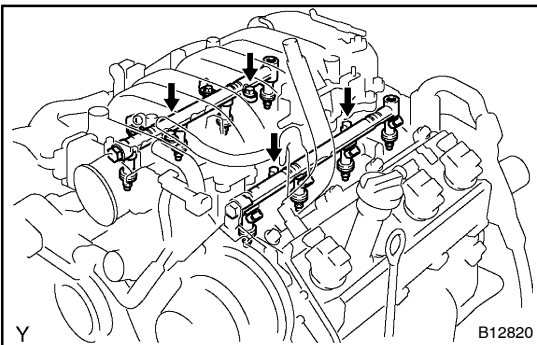

B12820

7. DISCONNECT ENGINE WIRE FROM DELIVERY PIPE
 - (a) Disconnect the 2 wire clamps from the wire clamp bracket on the RH delivery pipe.
 - (b) Disconnect the 8 injector connectors.
8. REMOVE DELIVERY PIPES AND INJECTORS

NOTICE:

- Be careful not to drop the injectors when removing the delivery pipes.
 - Pay attention to put any hung load on the injector to and from the side direction.
- (a) Remove the 4 nuts holding the delivery pipe to the intake manifold.
 - (b) Remove the 2 delivery pipes and 8 injectors assembly and 4 spacers.
 - (c) Pull out the 8 injectors from the delivery pipes.
 - (d) Remove the 2 O-rings, grommet and insulator from each injector.