

# CYLINDER HEAD COMPONENTS

EM02-03

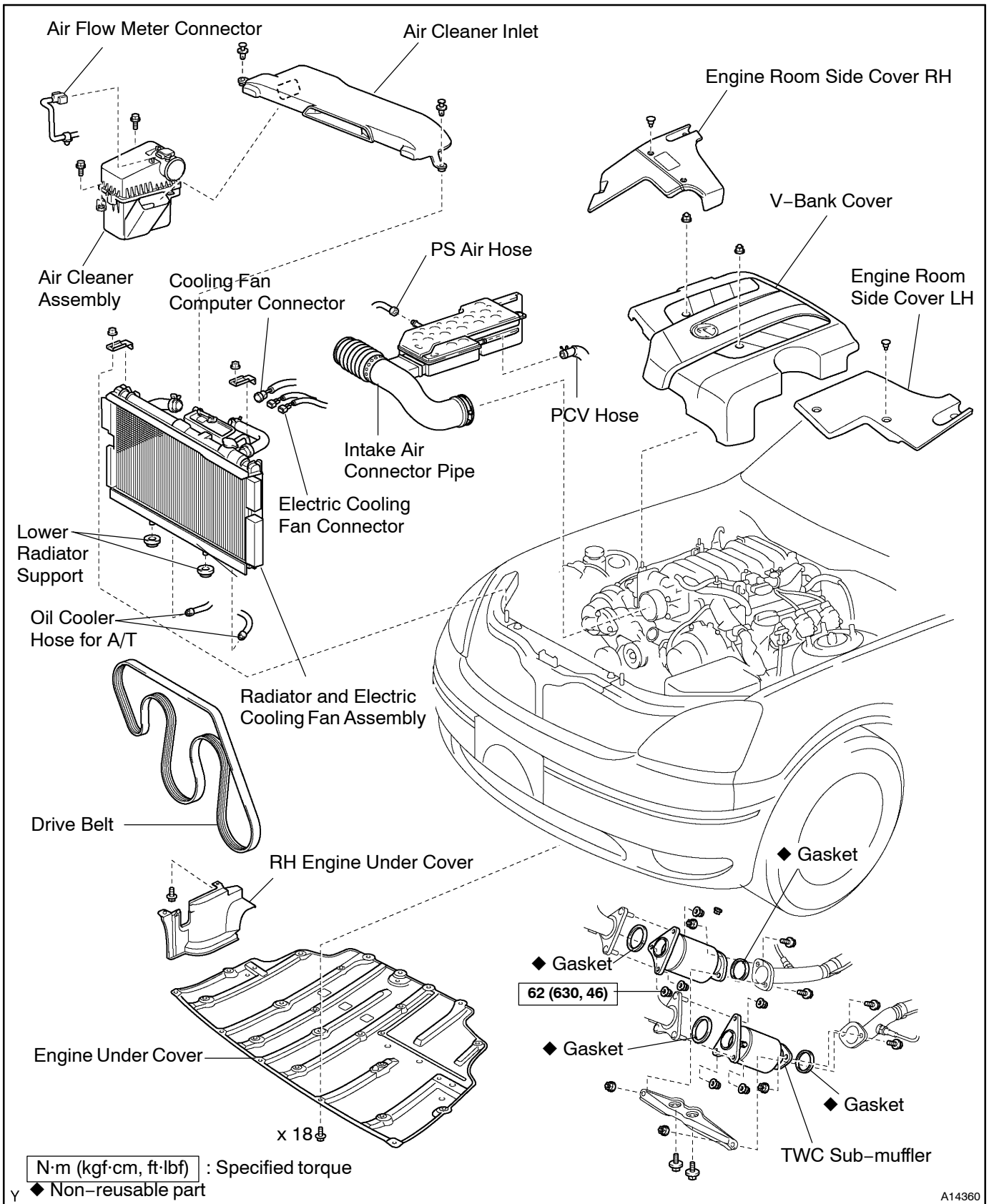

A14360

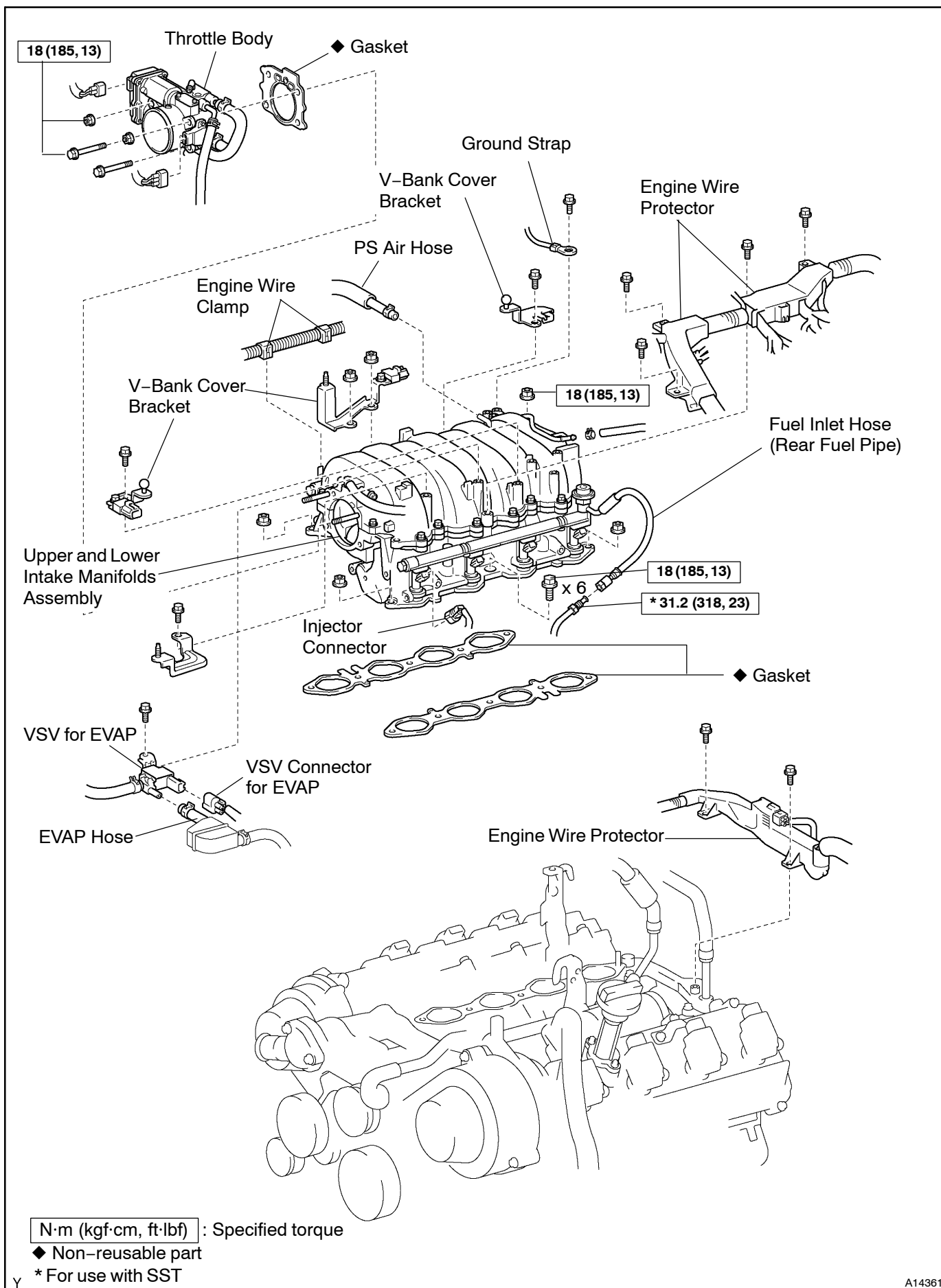

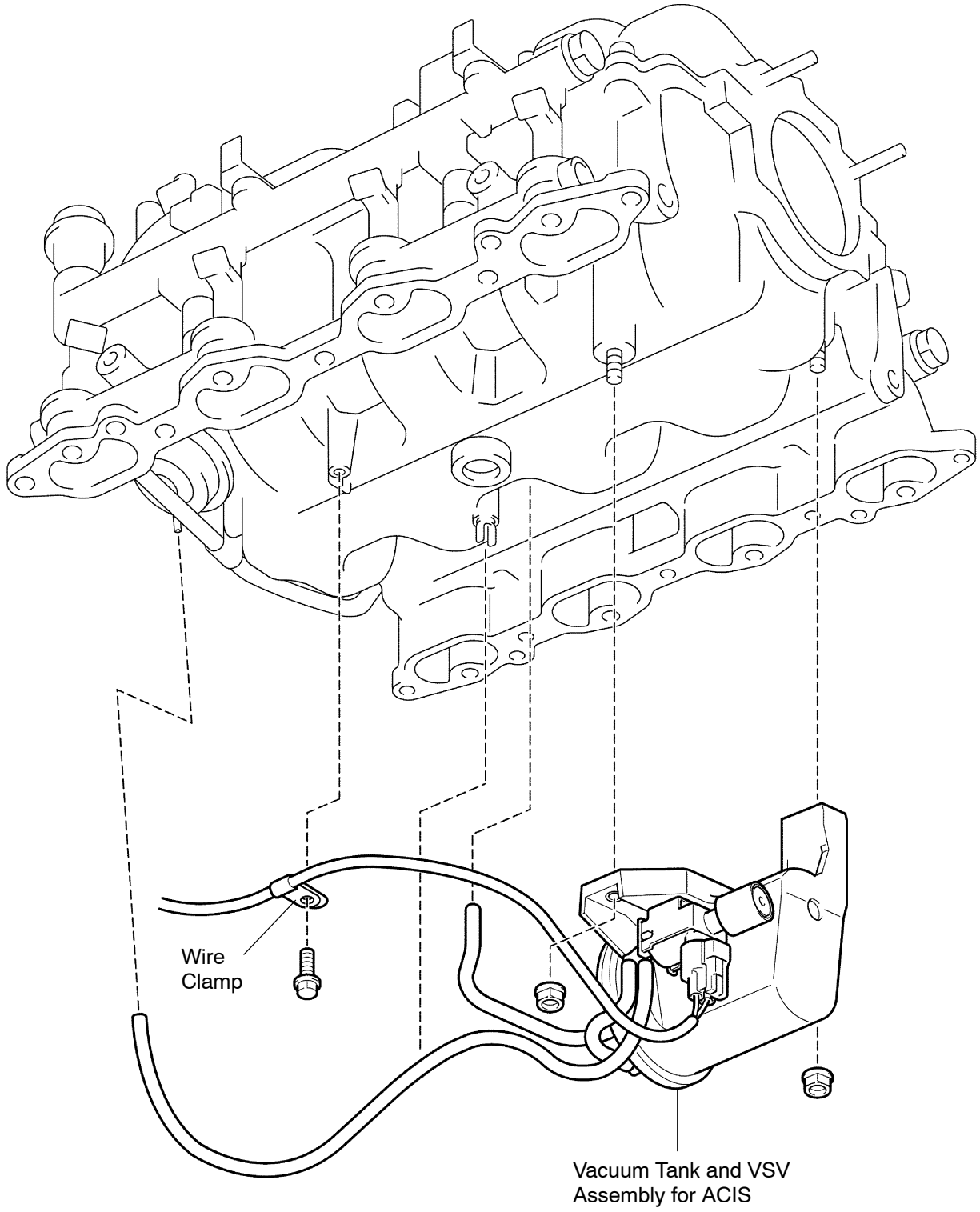

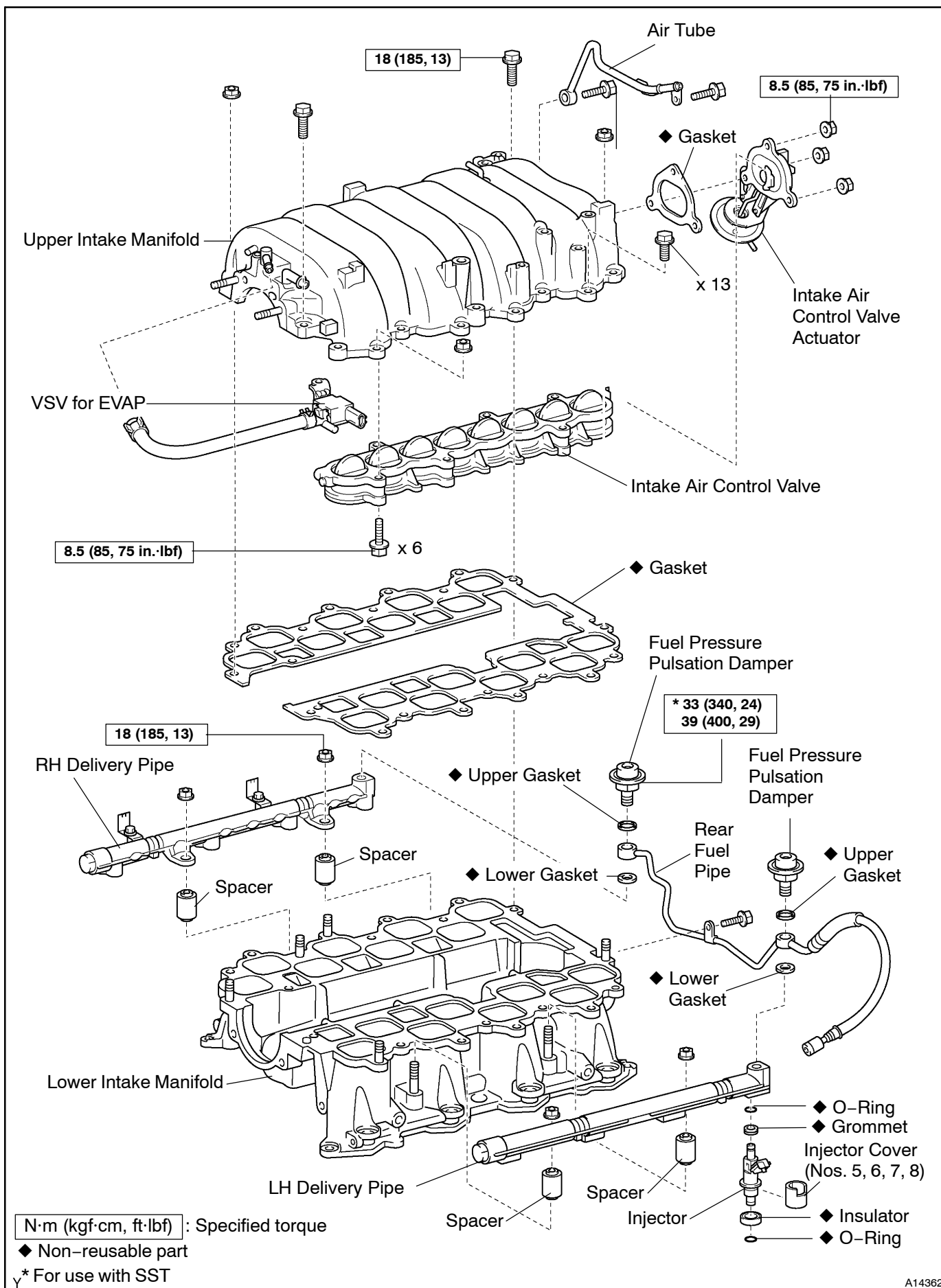

A14362

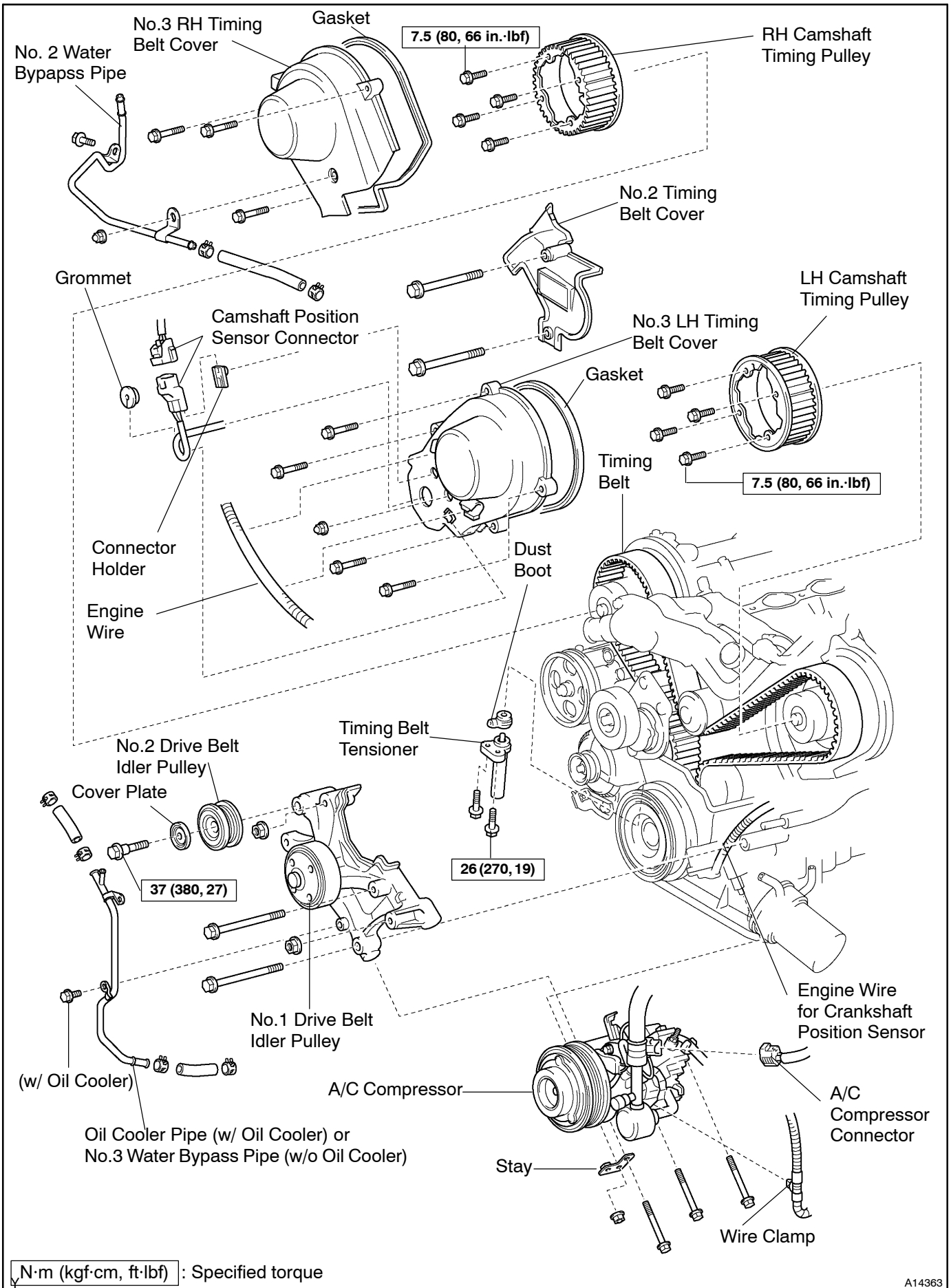

N·m (kgf·cm, ft·lbf) : Specified torque

A14363

