

DTC	B1415/15	Air Duct Sensor Circuit (Driver Side)
------------	-----------------	----------------------------------------------

CIRCUIT DESCRIPTION

This sensor detects the register temperature and sends the appropriate signals to the A/C ECU.

DTC No.	Detection Item	Trouble Area
B1415/15	Open or short in duct sensor circuit.	<ul style="list-style-type: none"> • Duct sensor. • Harness or connector between duct sensor and A/C ECU. • A/C ECU.

WIRING DIAGRAM

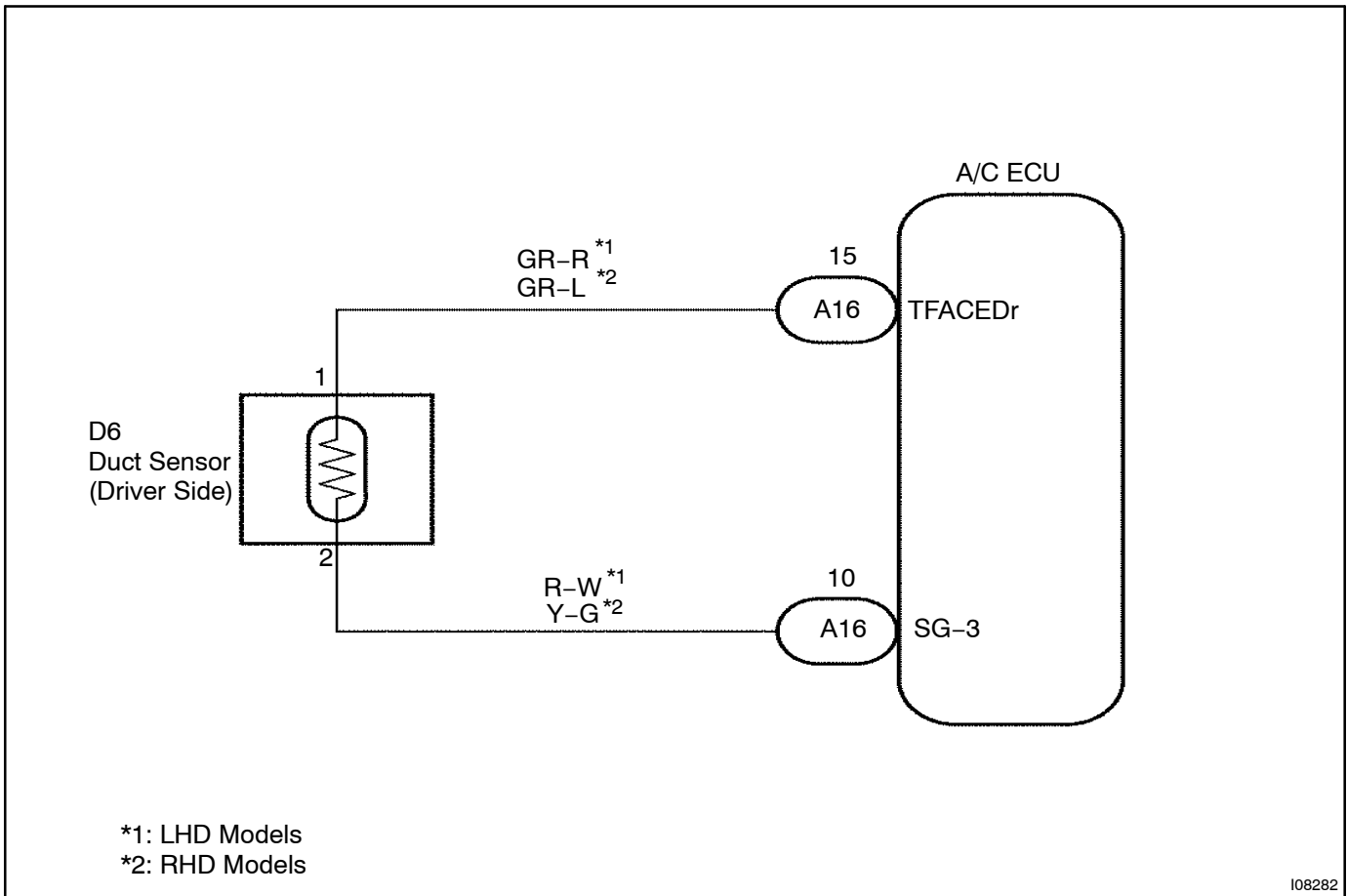

INSPECTION PROCEDURE

HINT:

In case of using the hand-held tester, start the inspection step 1 and in case of not using the hand-held tester, start from step 2.

1 Check air duct sensor using hand-held tester.

PREPARATION:

Connect the hand-held tester to the DLC3.

CHECK:

Check the air duct sensor using DATA LIST.

OK

Check and replace A/C ECU.

NG

2 Check voltage between terminals TFACEDr and SG-3 of A/C ECU connector.

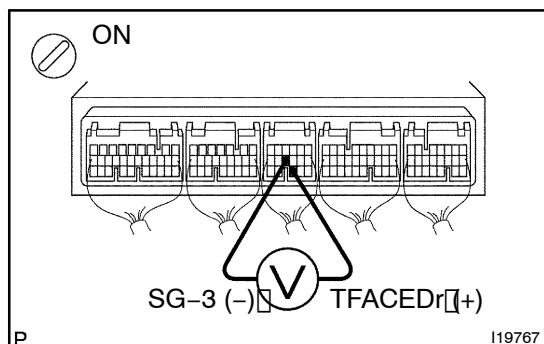

PREPARATION:

Remove A/C ECU with connectors still connected.

CHECK:

- Turn ignition switch to ON.
- Check voltage between terminals TFACEDr and SG-3 of A/C ECU connector at each register temperature.

OK:

Voltage:

at 25°C (77°F): 1.8 - 2.2V

at 50°C (122°F): 0.8 - 1.2V

HINT:

As the temperature increases, the voltage decreases.

NG

Go to step 3.

OK

Proceed to next circuit inspection shown on problem symptoms table (See page DI-1772). However, if DTC B1415/15 is displayed, check and replace A/C ECU.

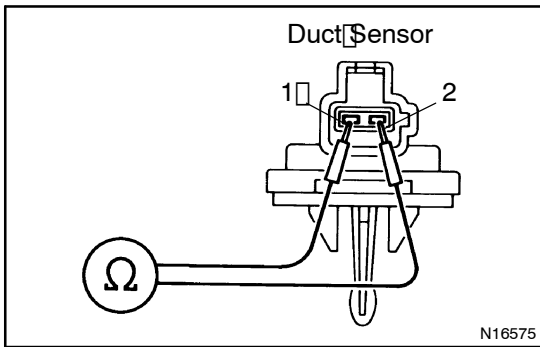
3 Check duct sensor.**PREPARATION:**

Remove duct sensor (See page AC-86).

CHECK:

Check resistance between terminals 1 and 2 of duct sensor connector at each temperature.

OK:**Resistance:**

at 0 °C (32 °F): 14.5 – 19.0 kΩ

at 25 °C (77 °F): 4.8 – 5.2 kΩ

at 50 °C (122 °F): 1.6 – 2.0 kΩ

HINT:

As the temperature increases, the resistance decreases.

NG**Replace duct sensor.****OK****4 Check harness and connector between A/C ECU and duct sensor (See page IN-35).****NG****Repair or replace harness or connector.****OK****Check and replace A/C ECU.**