

DTC	B1237	Jam Protection Limit Switch Circuit on Rear Left Door
------------	--------------	--

CIRCUIT DESCRIPTION

This DTC is output when failure of the jam protection limit switch circuit is detected.

The jam protection limit switch is built in the power window motor.

This switch is OFF when the window stays between the fully closed position and 4 mm under the full-closed position, and Rear LH Door ECU reads this signal.

DTC No.	DTC Detecting Condition	Trouble Area
B1237	No change in limit switch more than 2.0 seconds even if operating glass down when limit switch is OFF (window glass is fully closed)	<ul style="list-style-type: none"> • Jam protection limit switch • Wireharness • Rear Door LH ECU

HINT:

When the door ECU detects the condition that the power window is lowered to turn the limit switch from OFF to ON, this DTC is cleared.

WIRING DIAGRAM

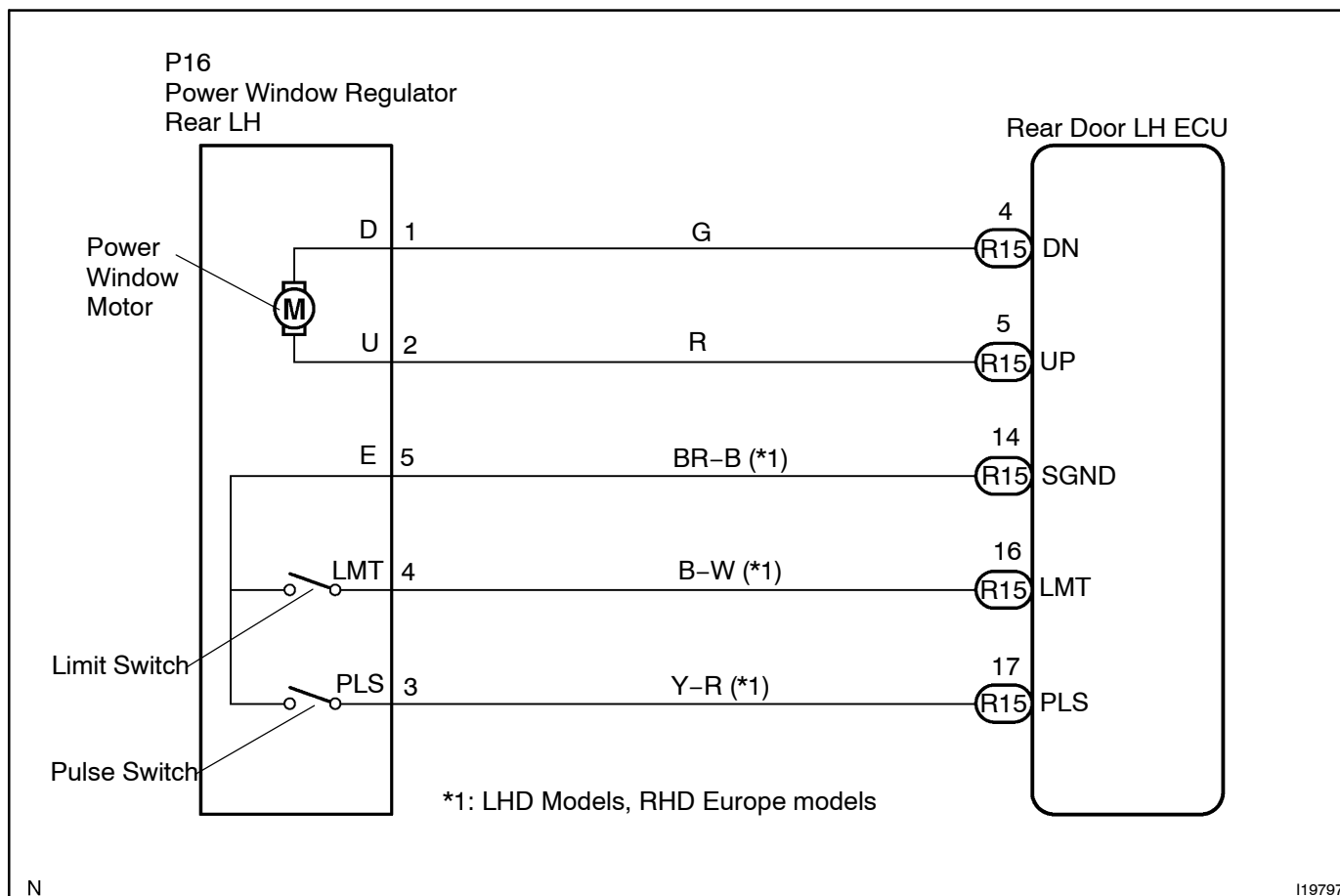

INSPECTION PROCEDURE**HINT:**

In case of not using the LEXUS hand-held tester, start from step 3.

- 1 Whether or not this DTC is cleared when the power window is lowered from fully close condition to half opened condition.

Yes

It is suspected that the DTC was detected by ECU with any failure in the past.

No

- 2 Check jam protection limit switch using LEXUS hand-held tester.

PREPARATION:

Connect the LEXUS hand-held tester to the DLC3.

CHECK:

Check the jam protection limit switch using DATA LIST.

OK

Replace rear door LH ECU (See page IN-24)

NG

- 3 Check jam protection limit switch (See page BE-85).

NG

Replace power window motor.

OK

- 4 Check wireharness and connector between jam protection limit switch and rear door LH ECU. (See page IN-35)

NG

Repair or replace wireharness or connector.

OK

Replace rear door LH ECU
(See page N-35).