

# Electro chromic mirror circuit

## CIRCUIT DESCRIPTION

The electro chromic mirror is built in the outer mirror assembly.

The outer electro chromic signal is sent to the room mirror via the Driver Door ECU.

## WIRING DIAGRAM

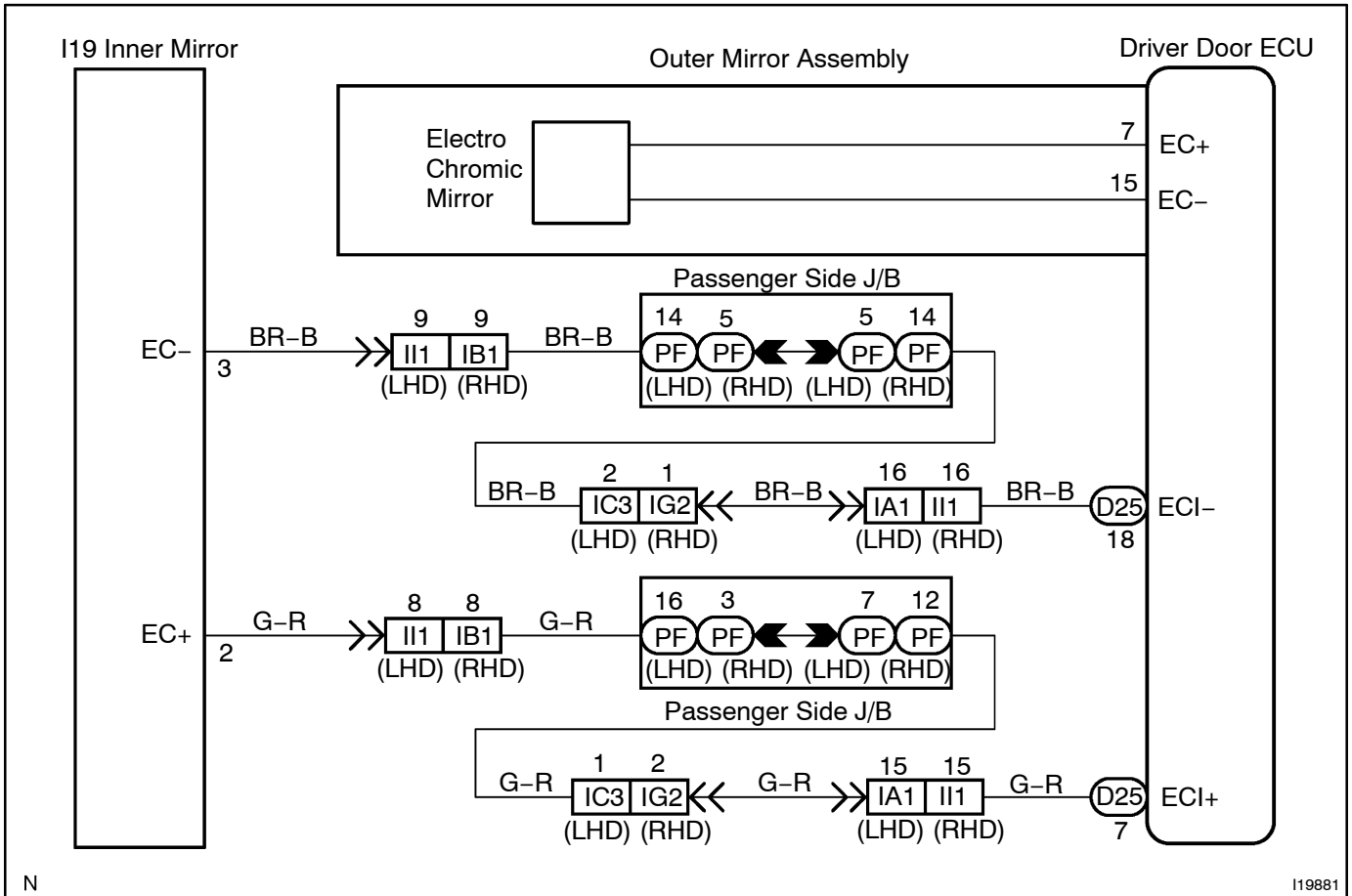

N

I19881

**INSPECTION PROCEDURE**

1 Check electrochromic mirror (See page BE-153).

NG

Replace mirror assembly.

OK

2 Check wire harness and connector between electrochromic mirror and driver door ECU (See page IN-35).

NG

Repair or replace wire harness or connector.

OK

Proceed to next circuit inspection shown on problem symptoms table (See page DI-1197).