

Luggage Compartment Door Closer Switch Circuit

CIRCUIT DESCRIPTION

The Luggage Door switch (LOPN, LCLS), which check the position of the luggage closer, and the Luggage Door Courtesy SW (LCTY), which checks the condition of the luggage, are installed in the luggage door lock assembly. The Luggage Door Lock switch (BDCY), which also checks the condition of the luggage is related to the operation of the luggage door.

The normal luggage door operation:

The closer turns counterclockwise toward the closer such as 1. Open completion position → 2. Close completion position → 3. Open standby position → 1. Open completion position. But in the trouble condition (when foreign materials are entered), the rotation direction of the closer is reversed to clockwise.

The relations between the Luggage Position Detection switch and the closer positions are as follows.

Closer Position	1. Open Completion Position	2. Close Completion Position (When the rotation is counterclockwise.)	2. Close Completion Position (When the rotation is clockwise.)	3. Open Standby Position
LOPN terminal	ON	OFF	ON	OFF
LCLS terminal	OFF	OFF	ON	ON
Luggage Door Condition.	Luggage door is open.	Luggage door is closed.	---	LOCK does not function due to its structure when the Latch is free.

1. CLOSER OPERATION

(a) Motor Operation under Normal Condition

The condition is that:

- The luggage closer is at the open completion position (the Luggage door (LOPN, LCLS) switch LOPN = ON, LCLS = OFF)
- The Luggage Door Lock SW (BDCY) is OFF.

If the Luggage Door Courtesy switch (LCTY terminal) is turned from ON to OFF (after 0.5 msec.), the luggage closer motor is run counterclockwise, and stopped at the close completion position (the Luggage door (LOPN, LCLS) switch LOPN = OFF, LCLS = OFF).

(b) Motor Operation under Abnormal Condition (Foreign materials are entered.)

If the closer completion position (the Luggage door (LOPN, LCLS) switch LOPN = OFF, LCLS = OFF) cannot be detected within 3 sec. after the closer operation is started, this is judged as a closer operation error (Foreign materials' entry is detected.), and the closer operation is stopped. After the motor is stopped for 100 msec. +−20 msec, the clockwise (reverse) open operation is conducted.

(c) Open Operation Demand During the Closer Operation

If any of the following conditions are found during the closer operation, the open operation is conducted.

The Luggage Push switch is ON.

The Luggage Room J/B ECU receives the luggage open demand signal from the Theft Deterrent ECU. The Luggage Open-Close switch is ON. (The Luggage Door Key Lock and Unlock switch and the luggage closer device are connected mechanically. Therefore, when the Luggage Door Key Lock and Unlock switch is operated, the Luggage Open-Close switch is turned ON.)

2. OPENER OPERATION

(a) Motor Operation under Normal Condition

When the luggage closer is in the closer completion position (Luggage door (LOPN, LCLS) switch LOPN = OFF, LCLS = OFF), if the luggage door OPEN demand signal is sent, the luggage closer motor runs counterclockwise and the open operation is conducted.

Then it stops at the open standby position (Luggage door (LOPN, LCLS) switch LOPN = OFF, LCLS = ON). At the open standby position, if the Luggage Door lock switch is turned from OFF to ON (The luggage door is open.), the luggage closer motor runs counterclockwise and stops at the open completion position (Luggage door (LOPN, LCLS) switch LOPN = ON, LCLS = OFF).

(b) Motor Operation under Abnormal Condition

The luggage closer is not in the closer completion position (Luggage door (LOPN, LCLS) switch LOPN = OFF, LCLS = OFF). When the signal from the Luggage Door Key lock and Unlock switch or the luggage open demand signal is received, this is judged as an error and the clockwise (reverse) open operation is conducted.

WIRING DIAGRAM

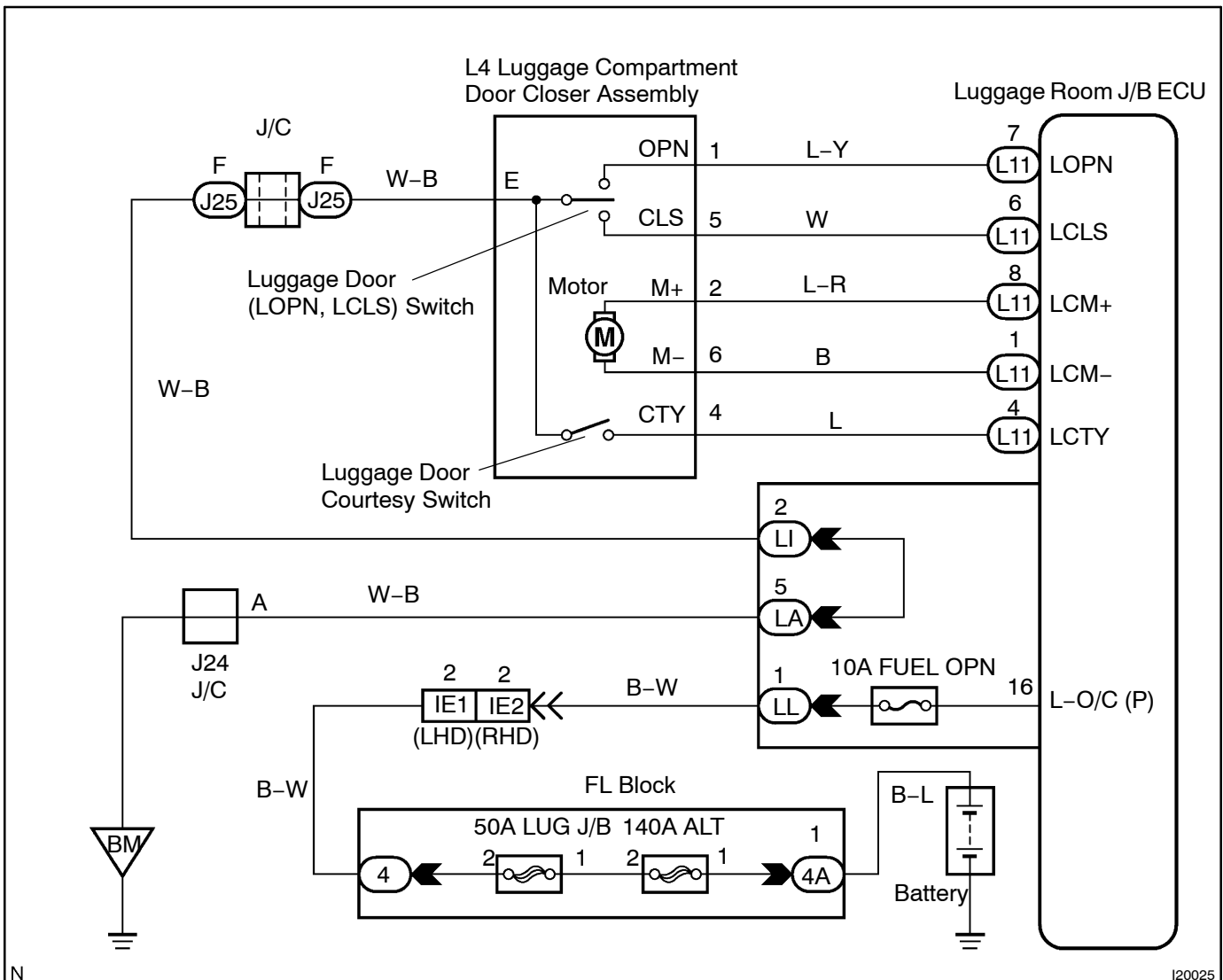

INSPECTION PROCEDURE

1 Check luggage compartment door closer switch using LEXUS hand-held tester.

PREPARATION:

Connect the LEXUS hand-held tester to the DLC3.

CHECK:

Check the luggage compartment door closer switch using DATA LIST.

OK

Proceed to next circuit inspection shown on problem symptom table (See page DI-1113).

NG

2 Check luggage compartment door closer switch (See page BE-174).

NG

Replace luggage compartment door closer switch.

OK

3 Check wireharness and connector between luggage compartment door closer switch and luggage room J/B ECU (See page N-35).

NG

Repair or replace wireharness or connector.

OK

Proceed to next circuit inspection shown on problem symptoms table (See page DI-1113).