

Variable motor circuit (Europe LHD Models)

CIRCUIT DESCRIPTION

Passenger side J/B ECU receives signals of the wiper switch, the rain sensor and others to operate the variable motor.

When the wiper switch is in INT position or in LO position, or the washer is operated in the washer-linked operation, Passenger side J/B ECU controls the variable motor to stop it at raise-up position.

However, when the vehicle speed is 106 mile/h (170 km/h) or more, it stops not at the raise-up position but at the least wiper link angle position.

If the variable motor is stopped at the raise-up position, Passenger side J/B ECU controls the variable motor considering the vehicle speed as 106 mile/h (170 km/h) or more unless the vehicle speed becomes less than 93 mile/h (150 km/h).

If the wiper switch is in HI speed, Passenger side J/B ECU controls the variable motor to stop it at the least wiper link angle position.

If the wiper motor stop command is received, the variable motor is moved to the retract position.

PA1, PA2 and PA3 terminals are position detection sensors of the variable motor.

Relations between variable motor position and the position detection sensor.

Variable motor position	PA1	PA2	PA3
Retract position	OFF	ON	ON
In operation	OFF	OFF	ON
Raise up position	ON	OFF	ON
In operation	OFF	OFF	OFF
The least wiper link angle position	OFF	ON	OFF

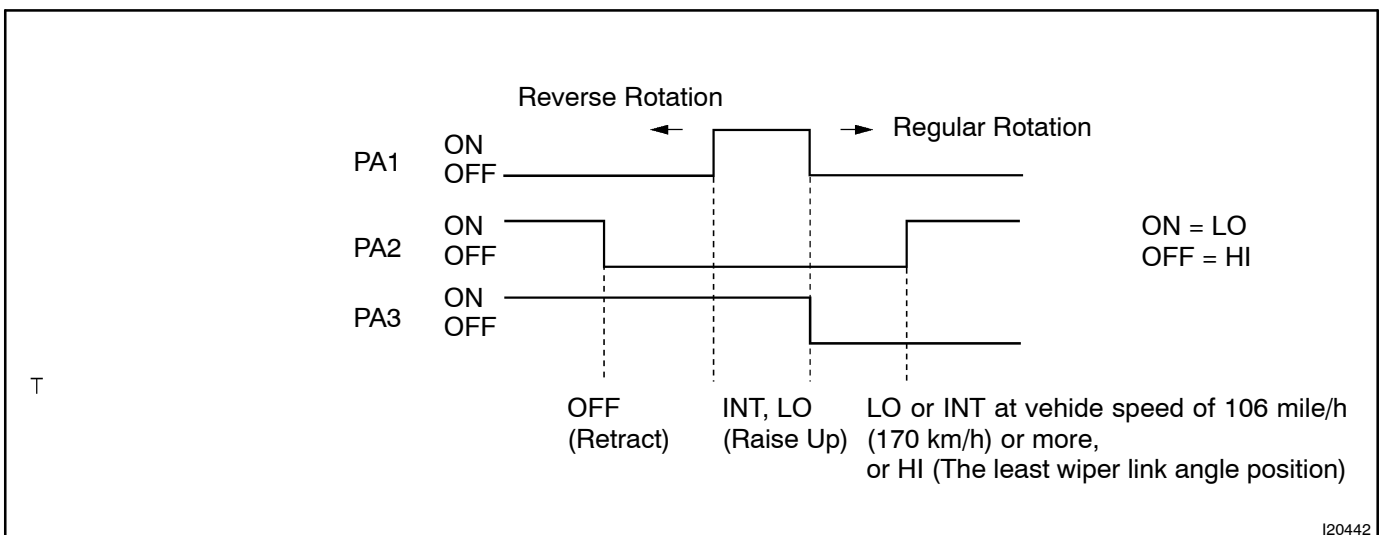

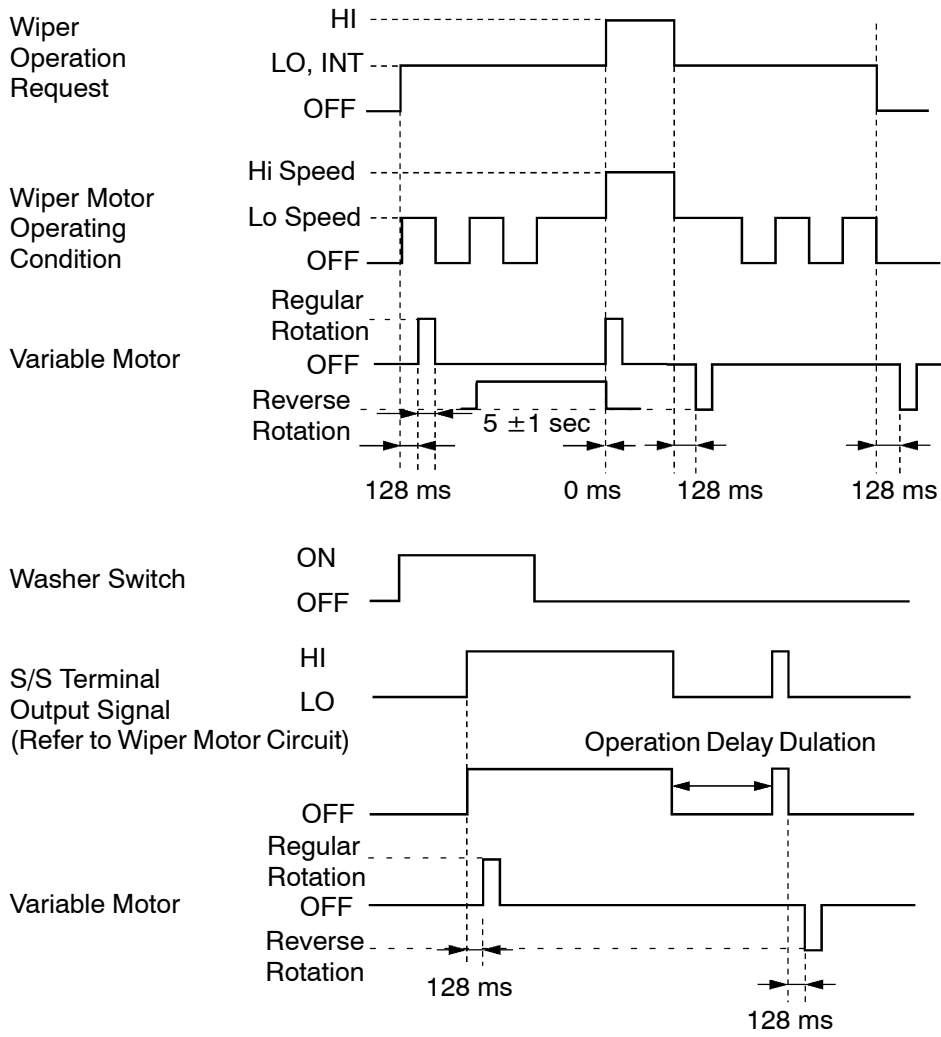

T

WIRING DIAGRAM

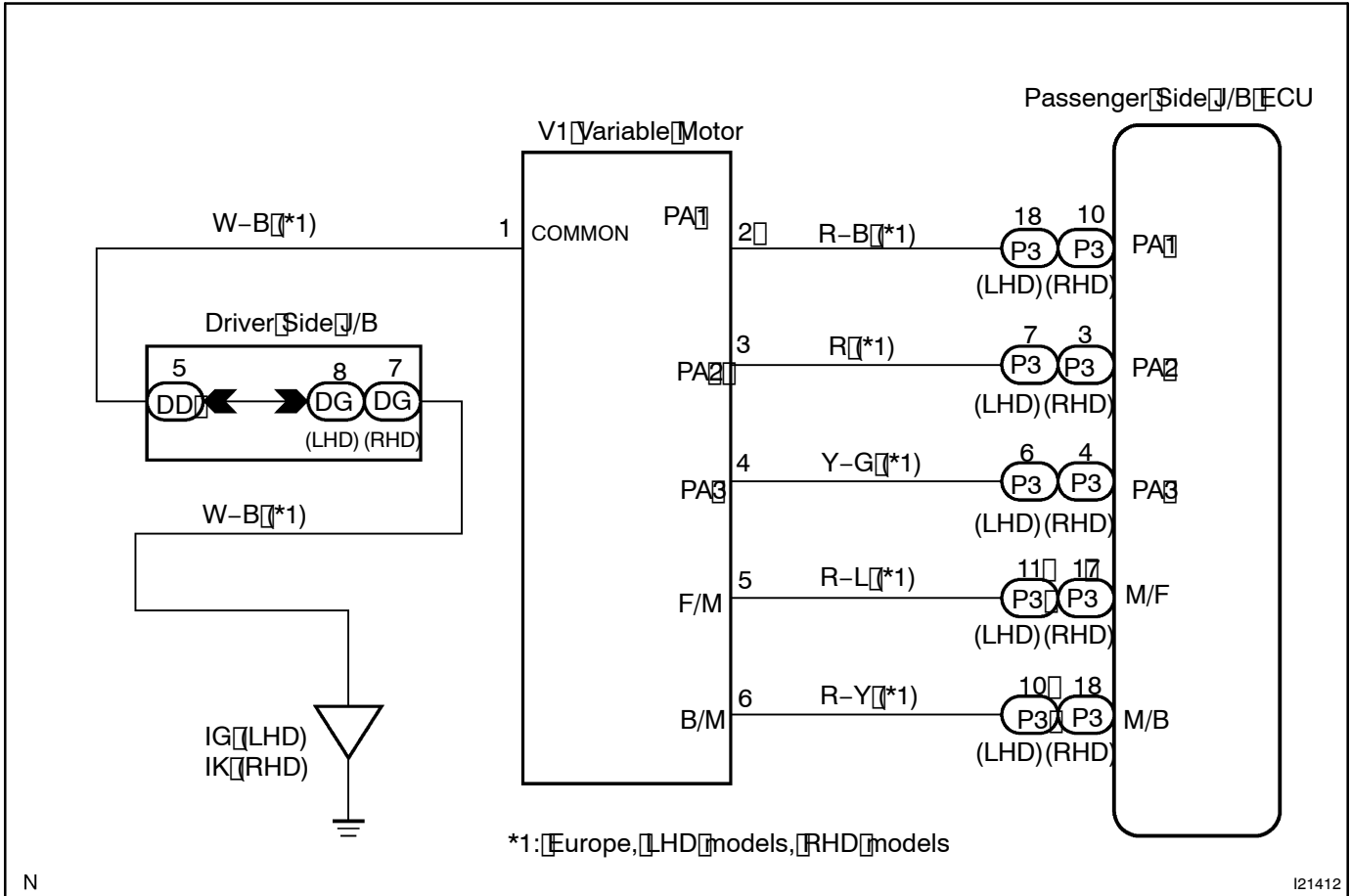

INSPECTION PROCEDURE

HINT:

In case of using the LEXUS hand-held tester, start the inspection from step 1 and in case of not using the LEXUS hand-held tester, start from step 2.

1	Check variable motor using LEXUS hand-held tester.
---	-----------------------------------------------------------

PREPARATION:

Connect the LEXUS hand-held tester to the DLC3.

CHECK:

Check that the variable motor can operate in an ACTIVE TEST.

OK	Proceed to next circuit inspection shown on problem symptoms table (See page DI-1071).
----	-----------------------------------------------------------------------------------------------

NG

2 Check motor (See page BE-64).

NG

Replace the motor.

OK

3 Check wire harness and connector between motor and passenger side J/B ECU (See page IN-35).

NG

Repair or replace wire harness or connector.

OK

Proceed to next circuit inspection shown on problem symptoms table (See page DI-1071).