

PRE-CHECK

1. DIAGNOSIS SYSTEM

- (a) Check the Indicator.
- (1) Turn the Ignition switch ON.
 - (2) Check that the CRUISE MAIN Indicator Light comes on when the cruise control main switch is turned on, and that the Indicator Light goes off when the main switch is turned OFF.

HINT:

If the indicator check result is not normal, proceed to troubleshooting (See page DI-930) for the combination meter section.

- (b) Check the DTC.

HINT:

If a malfunction occurs in the vehicle speed sensors or actuator, etc. during cruise control driving, the ECU actuates AUTO CANCEL of the cruise control and turns on and off the CRUISE MAIN indicator light to inform the driver of a malfunction. At the same time, the malfunction is stored in memory as a diagnostic trouble code.

- (c) Output of DTC using diagnosis check wire.
- (1) Turn the ignition switch ON.
 - (2) Using SST, connect terminals Tc and CG of DLC3.
SST 09843-18020
 - (3) Read the DTC on the CRUISE MAIN indicator light.

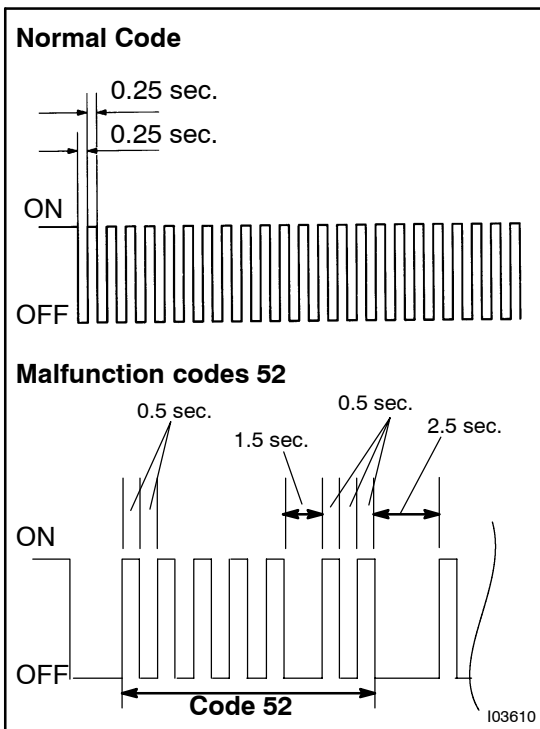
**HINT:**

If the DTC is not output, inspect the diagnosis circuit.

As an example, the blinking patterns for codes; normal, 52 are shown in the illustration.

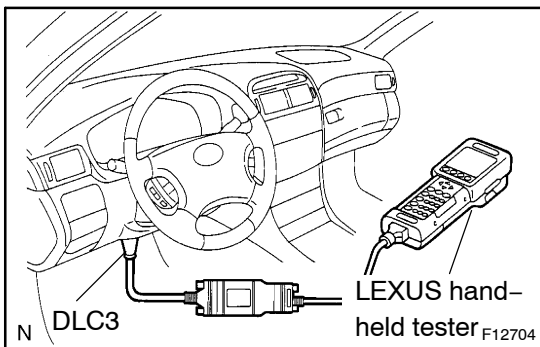
**2. USING LEXUS HAND-HELD TESTER**

- (a) Hook up the LEXUS hand-held tester to the DLC3.
- (b) Monitor the ECU data by following the prompts on the tester screen.

HINT:

LEXUS hand-held tester has a "Snapshot" function which records the monitored data.

Please refer to the LEXUS hand-held tester operator's manual for further details.

3. DTC CLEAR

The following actions erase the DTC and freeze frame data.

- (1) Operate the hand-held tester to erase the codes.
- (2) When not using hand-held tester, remove the EFI fuse from the engine room J/B for 10 sec. or more.