

DTC	B1193/66	Short in Rear P/T Squib (RH) Circuit (to B+)
------------	-----------------	---

CIRCUIT DESCRIPTION

The rear P/T squib (RH) circuit consists of the airbag sensor assembly and rear seat belt pretensioner (RH). It causes the SRS to deploy when the SRS deployment conditions are satisfied.

For details of the function of each component, see OPERATION on page RS-3.

DTC B1193/66 is recorded when a B+ short is detected in the rear P/T squib (RH) circuit.

DTC No.	DTC Detecting Condition	Trouble Area
B1193/66	<ul style="list-style-type: none"> • Short circuit in rear seat belt pretensioner (RH) wire harness (to B+) • Rear P/T squib (RH) malfunction • Airbag sensor assembly malfunction 	<ul style="list-style-type: none"> • Rear seat belt pretensioner (RH) • Airbag sensor assembly • Wire harness

WIRING DIAGRAM

See page DI-677.

INSPECTION PROCEDURE

1	Prepare for inspection (See step 1 on page DI-703).
----------	--

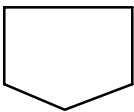

2	Check rear P/T squib (RH) circuit.
----------	---

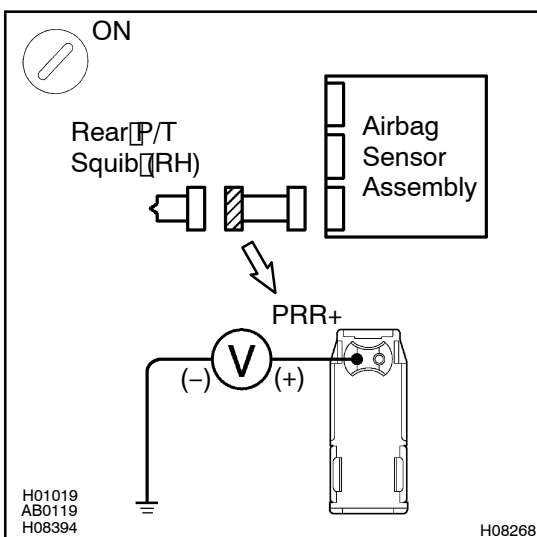

PREPARATION:

Deactivation of the LEXUS iLk system (See page DI-484).

CHECK:

- Turn the ignition switch to ON.
- For the connector (on the rear seat belt pretensioner side) between the rear seat belt pretensioner (RH) and the airbag sensor assembly, measure the voltage between PRR+ and body ground.

OK:

Voltage: 0 V



Repair or replace harness or connector between rear seat belt pretensioner (RH) and airbag sensor assembly.



3 Check airbag sensor assembly.

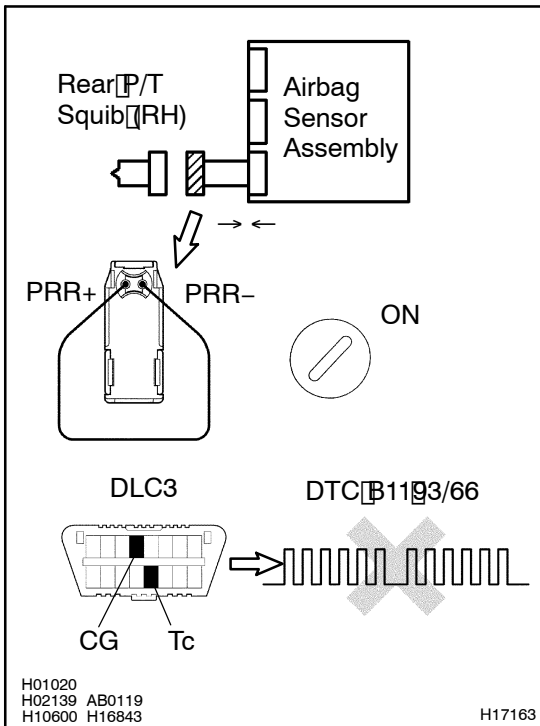

PREPARATION:

- Connect the connector to the airbag sensor assembly.
- Using a service wire, connect PRR+ and PRR- of the connector (on the rear seat belt pretensioner side) between the rear seat belt pretensioner (RH) and the airbag sensor assembly.
- Connect negative (-) terminal cable to the battery, and wait at least for 2 seconds.

CHECK:

- Turn the ignition switch to ON and wait at least for 20 seconds.
- Clear the DTC stored in memory (See step 5 on page DI-484).
- Turn the ignition switch to LOCK, and wait at least for 20 seconds.
- Turn the ignition switch to ON, and wait at least for 20 seconds.
- Check the DTC (See page DI-484).

OK:

DTC B1193/66 is not output.

HINT:

Codes other than code B1193/66 may be output at this time, but they are not relevant to this check.

NG

Replace airbag sensor assembly.

OK

4 Check rear P/T squib (RH).

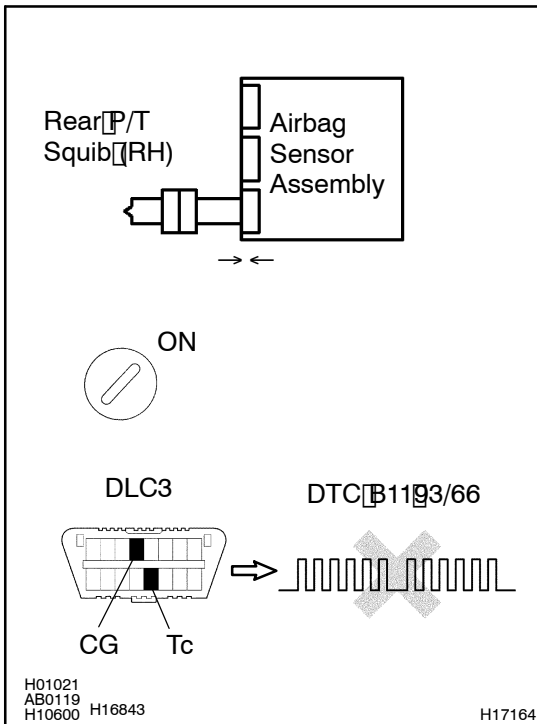

PREPARATION:

- Turn ignition switch to LOCK.
- Disconnect negative (-) terminal cable from the battery, and wait at least for 90 seconds.
- Connect the rear seat belt pretensioner (RH) connector.
- Connect negative (-) terminal cable to the battery, and wait at least for 2 seconds.

CHECK:

- Turn the ignition switch to ON, and wait at least for 20 seconds.
- Clear the DTC stored in memory (See step 5 on page DI-484).
- Turn the ignition switch to LOCK, and wait at least for 20 seconds.
- Turn the ignition switch to ON, and wait at least for 20 seconds.
- Check the DTC (See page DI-484).

OK:

DTC B1193/66 is not output.

HINT:

Codes other than code B1193/66 may be output at this time, but they are not relevant to this check.

NG

Replace rear seat belt pretensioner (RH).

OK

From the results of the above inspection, the malfunctioning part can now be considered normal. To make sure of this, use the simulation method to check. If the malfunctioning part can not be detected by the simulation method, replace all SRS components including the wire harness.