

DTC	B1186/58	Open in P Squib (2nd step) Circuit
------------	-----------------	---

CIRCUIT DESCRIPTION

The P Squib (2nd step) circuit consists of the airbag sensor assembly and front passenger airbag assembly. It causes the SRS to deploy when the SRS deployment conditions are satisfied.

For details of the function of each component, see OPERATION on page RS-3.

DTC B1186/58 is recorded when an open is detected in the P Squib (2nd step) circuit.

DTC No.	DTC Detecting Condition	Trouble Area
B1186/58	<ul style="list-style-type: none"> Open circuit in P2+ wire harness or P2- wire harness of squib P Squib (2nd step) malfunction Airbag sensor assembly malfunction 	<ul style="list-style-type: none"> Front passenger airbag assembly (P Squib (2nd step)) Airbag sensor assembly Wire harness

WIRING DIAGRAM

See page DI-664.

INSPECTION PROCEDURE

1	Prepare for inspection (See step 1 on page DI-703).
----------	--

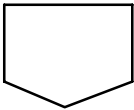

2	Check P squib (2nd step) circuit.
----------	--

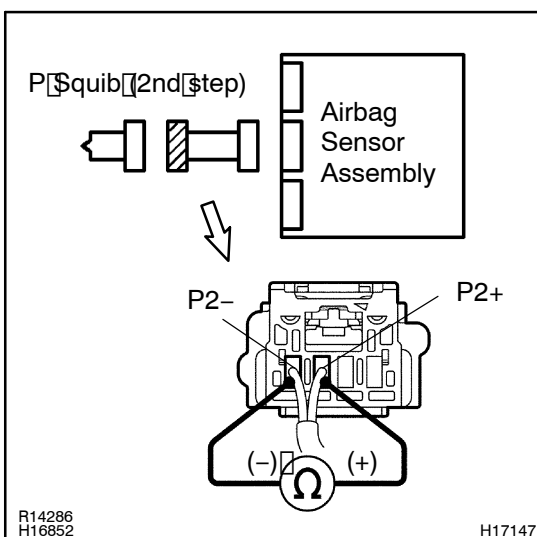

CHECK:

For the connector (on the front passenger airbag assembly side) between the front passenger airbag assembly and the airbag sensor assembly, measure the resistance between P2+ and P2-.

OK:

Resistance: Below 1 Ω



Repair or replace harness or connector between front passenger airbag assembly and airbag sensor assembly.



3 Check airbag sensor assembly.

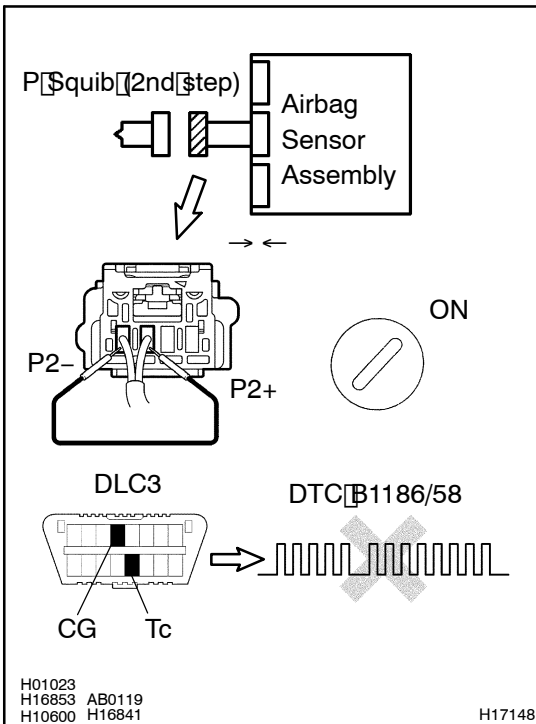

PREPARATION:

- Connect the connector to the airbag sensor assembly.
- Using a service wire, connect P2+ and P2- of the connector (on the front passenger airbag assembly side) between the front passenger airbag assembly and the airbag sensor assembly.
- Connect the negative (-) terminal cable to the battery, and wait at least for 2 seconds.

CHECK:

- Turn the ignition switch to ON and wait at least for 20 seconds.
- Clear the DTC stored in memory (See page DI-484).
- Turn the ignition switch to LOCK, and wait at least for 20 seconds.
- Turn the ignition switch to ON, and wait at least for 20 seconds.
- Check the DTC (See page DI-484).

OK:

DTC B1186/58 is not output.

HINT:

Codes other than code B1186/58 may be output at this time, but they are not relevant to this check.

NG

Replace airbag sensor assembly.

OK

4 Check P squib (2nd step).

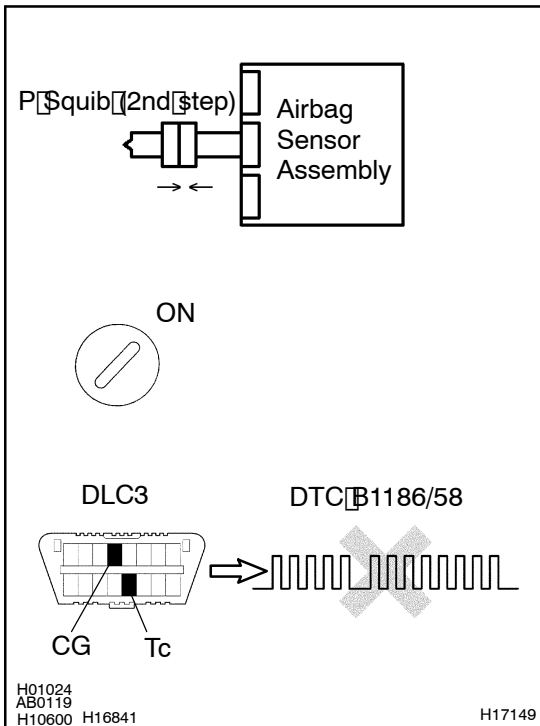

PREPARATION:

- Turn the ignition switch to LOCK.
- Disconnect the negative (-) terminal cable from the battery, and wait at least for 90 seconds.
- Connect the front passenger airbag assembly connector.
- Connect the negative (-) terminal cable to the battery, and wait at least for 2 seconds.

CHECK:

- Turn the ignition switch to ON, and wait at least for 20 seconds.
- Clear the DTC stored in memory (See page DI-484).
- Turn the ignition switch to LOCK, and wait at least for 20 seconds.
- Turn the ignition switch to ON, and wait at least for 20 seconds.
- Check the DTC (See page DI-484).

OK:

DTC B1186/58 is not output.

HINT:

Codes other than code B1186/58 may be output at this time, but they are not relevant to this check.

NG

Replace front passenger airbag assembly.

OK

From the results of the above inspection, the malfunctioning part can now be considered normal. To make sure of this, use the simulation method to check.