

DTC	B0132/61	Short in P/T Squib (RH) Circuit (to Ground)
------------	-----------------	--

CIRCUIT DESCRIPTION

The P/T squib (RH) circuit consists of the airbag sensor assembly and front seat belt pretensioner (RH). It causes the SRS to deploy when the SRS deployment conditions are satisfied.

For details of the function of each component, see OPERATION on page RS-3.

DTC B0132/61 is recorded when a ground short is detected in the front P/T squib (RH) circuit.

DTC No.	DTC Detecting Condition	Trouble Area
B0132/61	<ul style="list-style-type: none"> • Short circuit in front P/T squib (RH) wire harness (to ground) • Front P/T squib (RH) malfunction • Airbag sensor assembly malfunction 	<ul style="list-style-type: none"> • Front seat belt pretensioner (RH) • Airbag sensor assembly • Wire harness

WIRING DIAGRAM

See page DI-484.

INSPECTION PROCEDURE

1	Prepare for inspection (See step 1 on page DI-484).
---	---

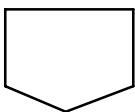

2	Check front P/T squib (RH) circuit.
---	-------------------------------------

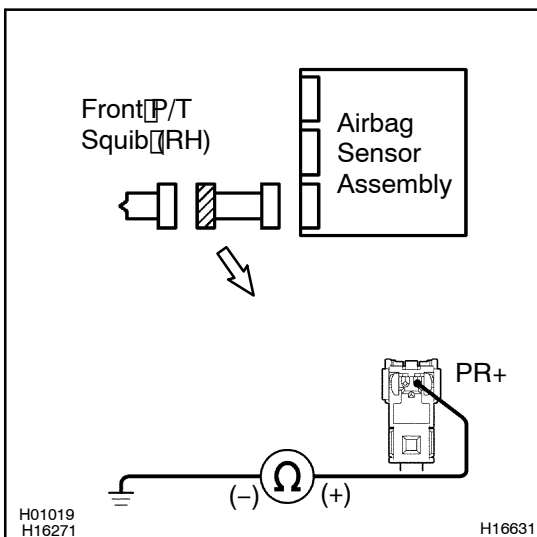

CHECK:

For the connector (on the front seat belt pretensioner side) between the front seat belt pretensioner (RH) and the airbag sensor assembly, measure the resistance between PR+ and body ground.

OK:

Resistance: 1 MΩ or Higher



Repair or replace harness or connector between front seat belt pretensioner (RH) and airbag sensor assembly.



3 Check airbag sensor assembly.

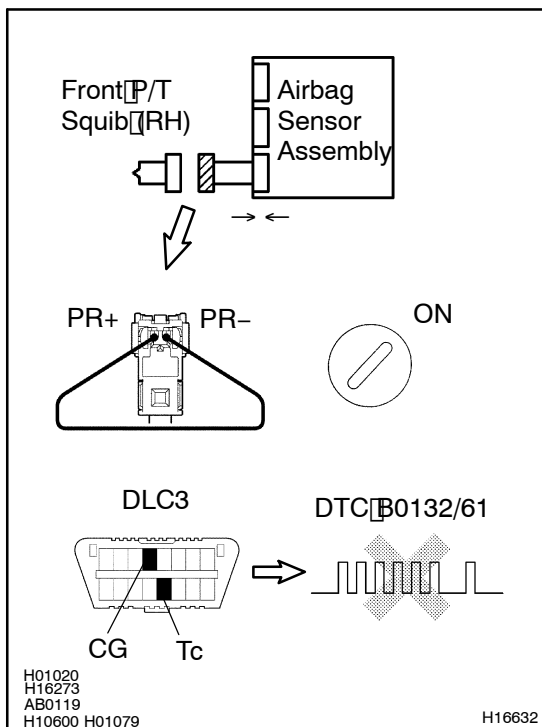

PREPARATION:

- Connect the connector to the airbag sensor assembly.
- Using a service wire, connect PR+ and PR- of the connector (on the front seat belt pretensioner side) between the front seat belt pretensioner (RH) and the airbag sensor assembly.
- Connect negative (-) terminal cable to the battery, and wait at least for 2 seconds.

CHECK:

- Turn the ignition switch to ON and wait at least for 20 seconds.
- Clear the DTC stored in memory (See step 5 on page DI-484).
- Turn the ignition switch to LOCK, and wait at least for 20 seconds.
- Turn the ignition switch to ON, and wait at least for 20 seconds.
- Check the DTC (See page DI-484).

OK:

DTC B0132/61 is not output.

HINT:

Codes other than code B0132/61 may be output at this time, but they are not relevant to this check.

NG

Replace airbag sensor assembly.

OK

4 Check front P/T squib (RH).

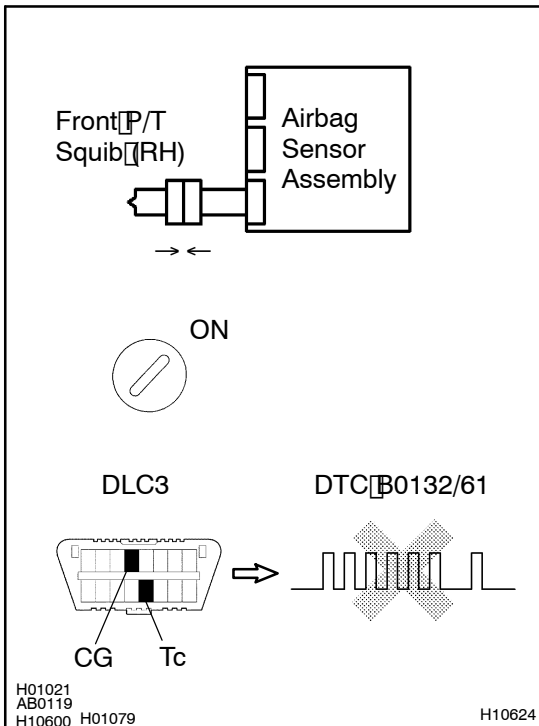

PREPARATION:

- Turn the ignition switch to LOCK.
- Disconnect the negative (-) terminal cable from the battery, and wait at least for 90 seconds.
- Connect the front seat belt pretensioner (RH) connector.
- Connect the negative (-) terminal cable to the battery, and wait at least for 2 seconds.

CHECK:

- Turn the ignition switch to ON, and wait at least for 20 seconds.
- Clear the DTC stored in memory (See step 5 on page DI-484).
- Turn the ignition switch to LOCK, and wait at least for 20 seconds.
- Turn the ignition switch to ON, and wait at least for 20 seconds.
- Check the DTC (See page DI-484).

OK:

DTC B0132/61 is not output.

HINT:

Codes other than code B0132/61 may be output at this time, but they are not relevant to this check.

NG

Replace front seat belt pretensioner (RH).

OK

From the results of the above inspection, the malfunctioning part can now be considered normal. To make sure of this, use the simulation method to check. If the malfunctioning part can not be detected by the simulation method, replace all SRS components including the wire harness.