

Kick-down Switch Circuit (Europe only)

CIRCUIT DESCRIPTION

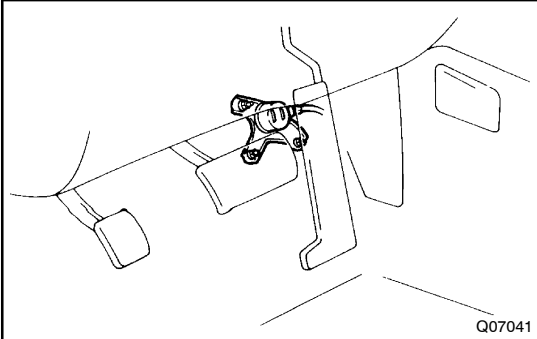

The kick-down switch is turned ON when the accelerator pedal is depressed to the full throttle and sends signals to Engine & ECT ECU.

When the kick-down switch is turned ON, the Engine & ECT ECU controls gear shifting according to the programmed shift diagrams.

If a short circuit develops in the kick-down switch, the Engine & ECT ECU disregards the kick-down signals and controls shifting at the normal shift points.

WIRING DIAGRAM

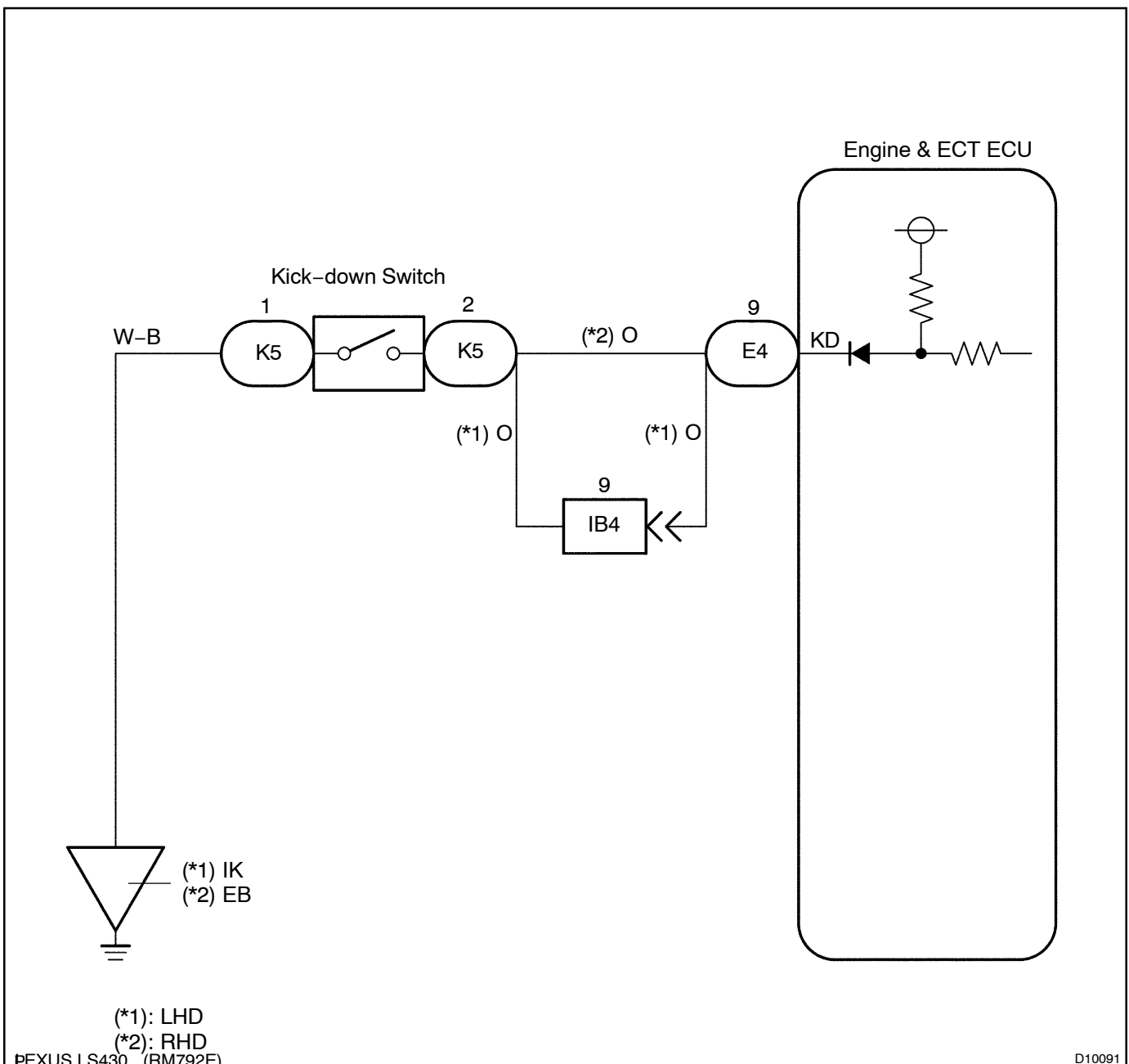

INSPECTION PROCEDURE

1 Check voltage between terminal KD of Engine & ECT ECU and body ground.

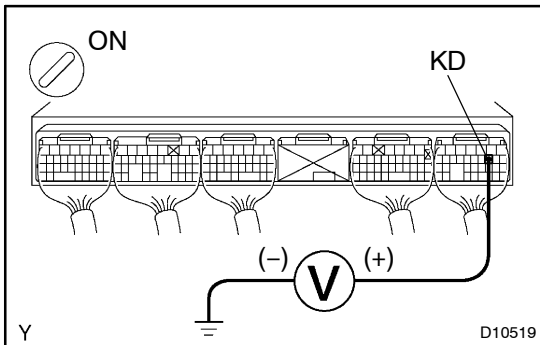
**PREPARATION:**

Turn the ignition switch ON.

CHECK:

Measure voltage between terminal KD of Engine & ECT ECU and body ground when accelerator pedal is fully depressed or not.

OK:

Accelerator pedal	Voltage
Fully depressed (Kick-down switch is ON)	Below 1 V
Released (Kick-down switch is OFF)	10 - 14 V

OK

Proceed to next circuit inspection shown in problem symptoms table (See page DI-191).

NG

2 Check kick-down switch.

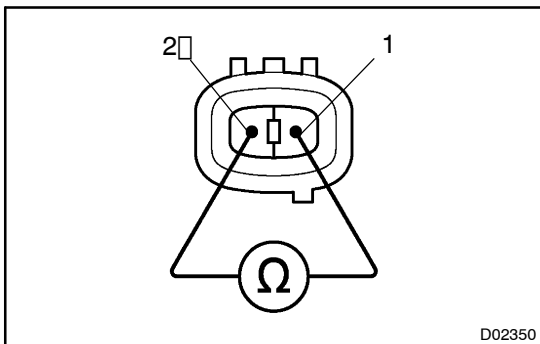
**PREPARATION:**

Disconnect the kick-down switch connector.

CHECK:

Measure continuity between terminals 1 and 2 of the kick-down switch connector when kick-down switch is ON and OFF.

OK:

Kick-down switch	Continuity
ON	Continuity
OFF	No continuity

NG

Replace the kick-down switch.

OK

3 Check harness and connector between Engine & ECT ECU and kick-down switch, kick-down switch and body ground (See page IN-35).

NG

Repair or replace harness or connector.

OK

Check and replace Engine & ECT ECU (See page IN-35).