

DTC	P1760/77	Linear Solenoid for Line Pressure Control Circuit Malfunction (SLT Solenoid Valve)
------------	-----------------	---

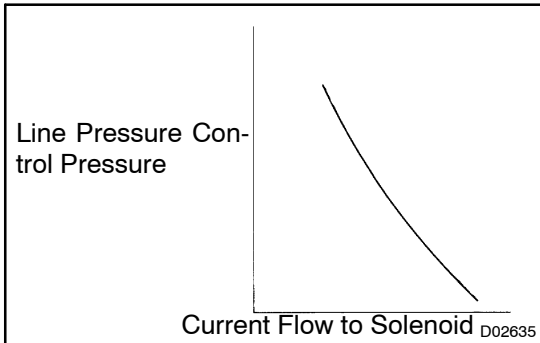

CIRCUIT DESCRIPTION

The throttle pressure that is applied to the primary regulator valve (which modulates line pressure) causes the SLT solenoid valve, under electronic control, to precisely and minutely modulates and generates line pressure according to the accelerator pedal effort, or engine power output detected.

This reduces the function of line pressure and provides smooth shifting characteristics.

Upon receiving the throttle valve opening angle signal, Engine & ECT ECU controls the line pressure by sending a predetermined (*) duty ratio to the solenoid valve, modulating the line pressure, generating throttle pressure.

(*) Duty Ratio

The duty ratio is the ratio of the period of continuity in one cycle. For example, if A is the period of continuity in one cycle, and B is the period of non-continuity, then

$$\text{Duty Ratio} = \frac{A}{A + B} \times 100 (\%)$$

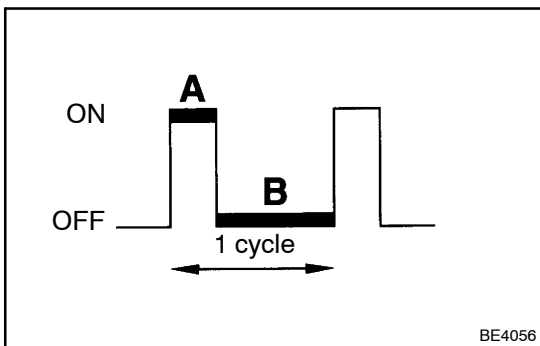

DTC No.	DTC Detecting Condition	Trouble Area
P1760/77	1. or 2. condition below is detected for 1 second or more. 1. SLT ⁻ terminal: 0 V 2. SLT ⁻ terminal: 12 V	<ul style="list-style-type: none"> • Open or short in SLT solenoid valve circuit • SLT solenoid valve • Engine & ECT ECU

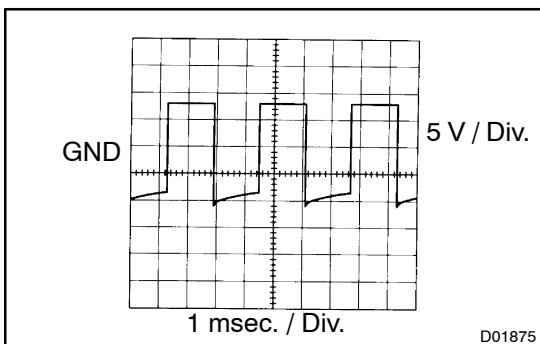

Reference:

Refer to the chart for the wave form between terminals SLT⁺ and SLT⁻during engine idling.

WIRING DIAGRAM

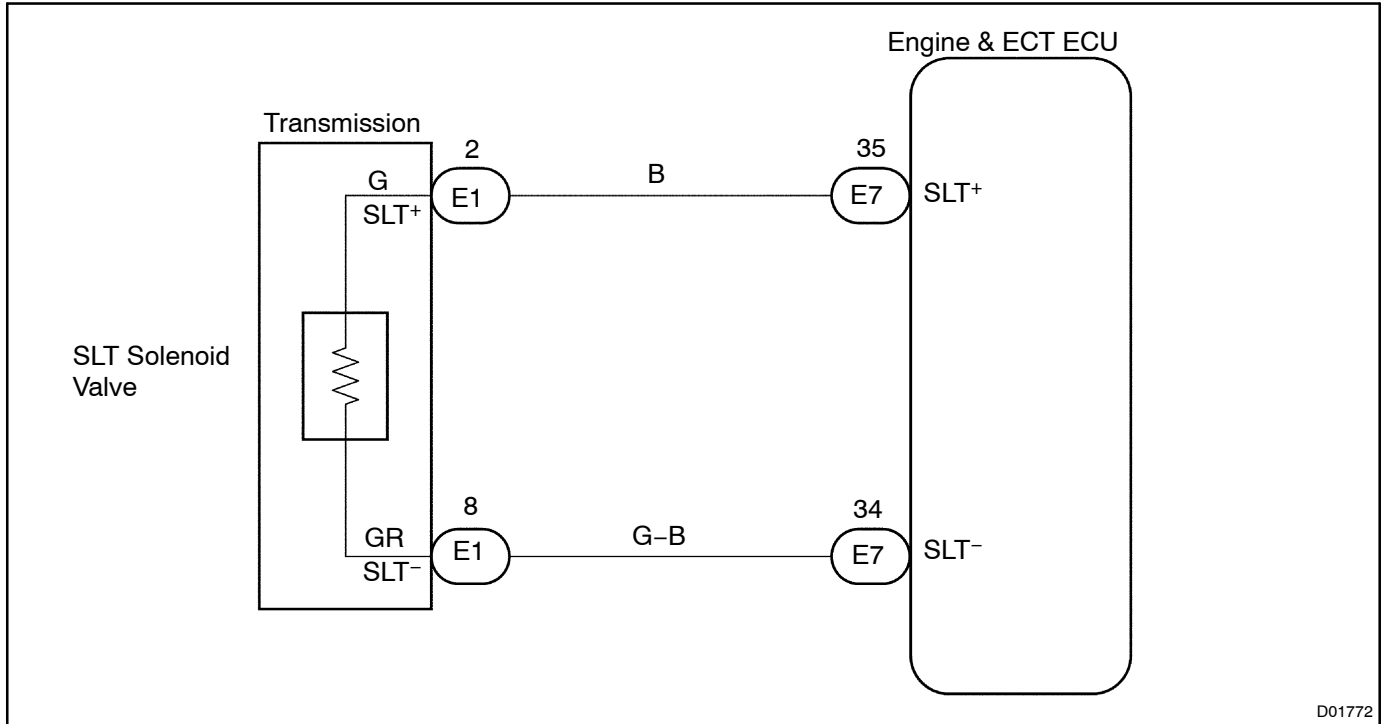

INSPECTION PROCEDURE

1 Check SLT solenoid valve.

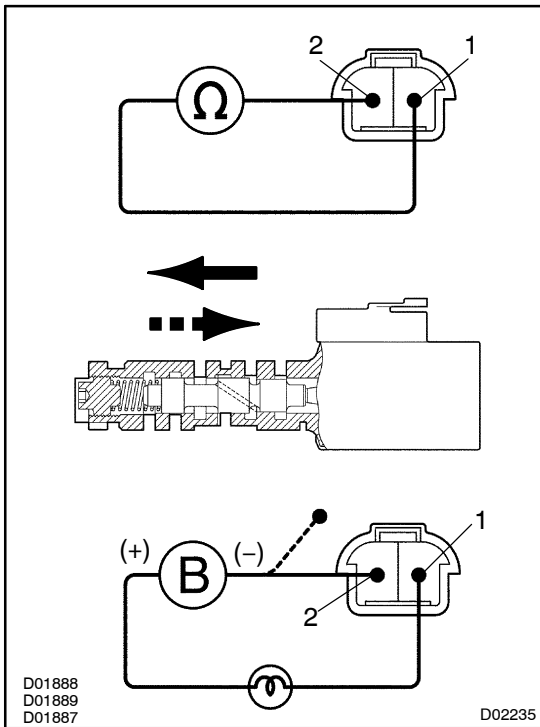
**PREPARATION:**

- (a) Jack up the vehicle.
- (b) Remove the oil pan.
- (c) Disconnect the solenoid connector.

Check solenoid resistance:**CHECK:**

Measure resistance between terminals 1 and 2 of solenoid connector.

OK:

Resistance: 5.0 - 5.6 Ω at 20 °C (68 °F)

Check solenoid operation:**CHECK:**

Connect positive (+) lead with an 8 - 10 W bulb to terminal 1 of solenoid connector and negative (-) lead to terminal 2, then check the movement of the valve.

OK:

When battery positive voltage is applied.	Valve moves in the direction in the illustration on the left.
When battery positive voltage is cut off.	Valve moves in the direction in the illustration on the left.

NG

Replace SLT solenoid valve.

OK

2 Check harness and connector between SLT solenoid valve and Engine & ECT ECU (See page N-35).

NG

Repair or replace harness or connector.

OK

Check and replace Engine & ECT ECU
(See page N-35).