

DTC	P1755/68	Liner Solenoid for Lock-up Control Circuit Malfunction (Shift Solenoid Valve SLU)
------------	-----------------	--

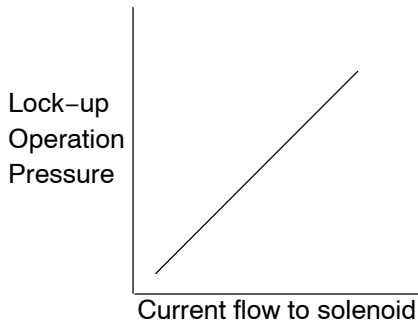

CIRCUIT DESCRIPTION

The amount of current flow to the solenoid is controlled by the (*) duty ratio of the ECM output signal. The higher the duty ratio becomes, the higher the lock-up hydraulic pressure becomes during the lock-up operation.

(*) Duty Ratio

The duty ratio is the ratio of the period of continuity in one cycle. For example, if A is the period of continuity in one cycle, and B is the period of non-continuity, then

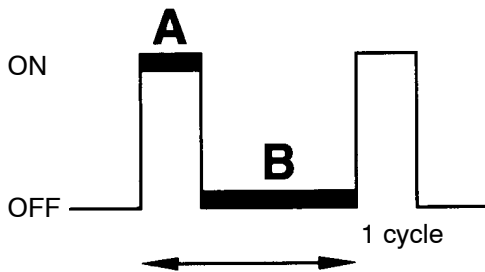

(*)

$$\text{Duty Ratio} = \frac{A}{A + B} \times 100 (\%)$$

BE4056

D00160

DTC No.	DTC detection condition	Trouble Area
P1755/68	The following condition is detected. (2 trip detection logic) SLU output signal's duty ON of 3.3 msec. or more with duty ratio of least 95% lasts for 1 second.	<ul style="list-style-type: none"> • Open or short in shift solenoid valve SLU circuit • Shift solenoid valve SLU • ECM

WIRING DIAGRAM

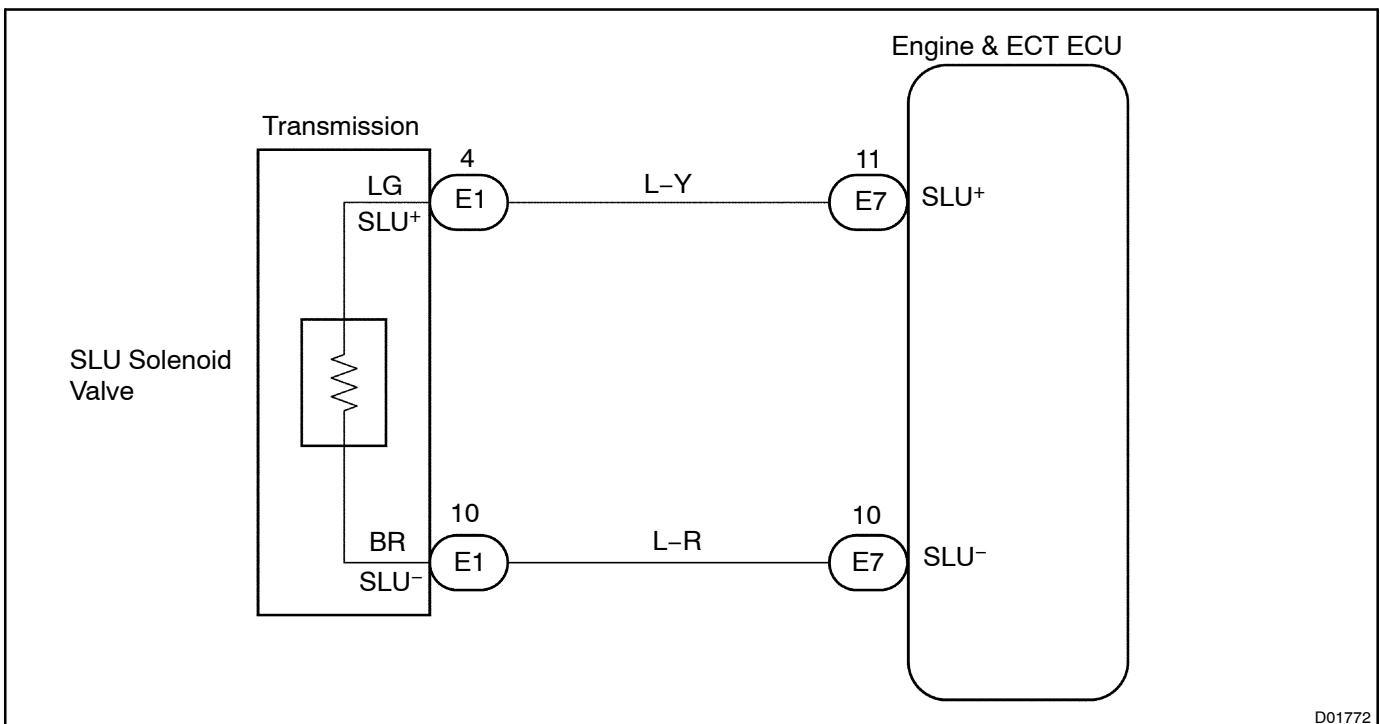

D01772

INSPECTION PROCEDURE

- 1 Check that the resistance between terminals 4 and 10 of transmission wire connector (See page DI-218).

NG Go to step 3.

OK

- 2 Check shift solenoid SLU.

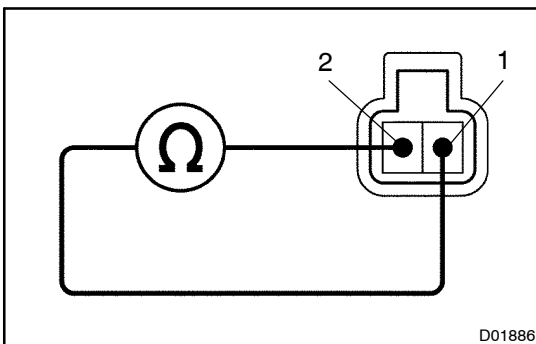
**PREPARATION:**

- (a) Jack up the vehicle.
 (b) Remove the oil pan.
 (c) Disconnect the solenoid connector.

CHECK:

Measure the resistance between terminals 1 and 2.

OK:

Voltage: 5.0 - 5.6 Ω

NG Replace shift solenoid valve SLU.

OK

- 3 Check harness and connector between shift solenoid valve SLU and ECM (See page N-35).

NG Repair or replace the harness or connector.

OK

Check and replace the ECM.