

PRE-CHECK

1. DIAGNOSIS SYSTEM

(a) Description

- When troubleshooting Euro-OBD vehicles, the only difference from the usual troubleshooting procedure is that you connect to the vehicle the OBD scan tool complying with ISO 15031-4 or handheld tester, and read off various data output from the vehicle's engine ECU.

Euro-OBD regulations require that the vehicle's on-board computer lights up the check engine warning light (CHK ENG) on the instrument panel when the computer detects a malfunction in the emission control system/components or in the power-train control components which affect vehicle emissions, or a malfunction in the computer. In addition to the CHK ENG lighting up when a malfunction is detected, the applicable Diagnostic Trouble Codes (DTCs) prescribed by ISO 15031-6 are recorded in the engine ECU memory (See page DI-16). If the malfunction does not repaired in 3 consecutive trips, the (CHK ENG) goes off automatically but the DTCs remain recorded in the engine ECU memory.

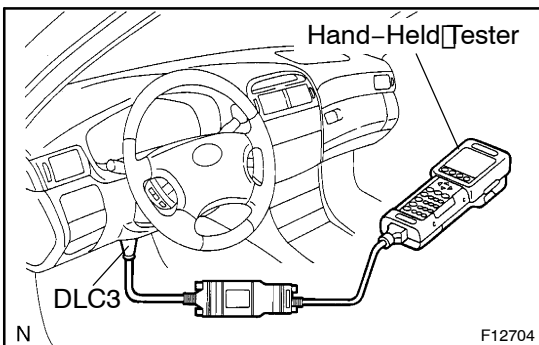

- To check the DTCs, connect the OBD scan tool or hand-held tester to the Data Link Connector (DLC3) on the vehicle. The OBD scan tool or hand-held tester also enables you to erase the DTCs and check freeze frame data and various forms of engine data (For operating instructions, see the OBD scan tool's instruction book.).

DTCs include ISO controlled codes and manufacturer controlled codes. ISO controlled codes must be set as prescribed by the ISO, while manufacturer controlled codes can be set freely by the manufacturer within the prescribed limits (See DTC chart on page DI-16).

- The diagnosis system operates in normal mode during normal vehicle use. It also has a check mode for technicians to simulate malfunction symptoms and troubleshoot. Most DTCs use 2-trip detection logic* to prevent erroneous detection, and ensure thorough malfunction detection. By switching the engine ECU to check mode when troubleshooting, the technician can cause the check engine warning light to light up for a malfunction that is only detected once or momentarily (Hand-held tester only) (See step 2).
- *2-trip detection logic:
When a malfunction is first detected, the malfunction is stored or rarely stored in the engine ECU memory. (1st trip) If the same malfunction is detected again during the second drive test, this second detection causes the (CHK(ENG)) to light up (2nd trip).
(However, the ignition switch must be turned OFF between the 1st trip and the 2nd trip.)

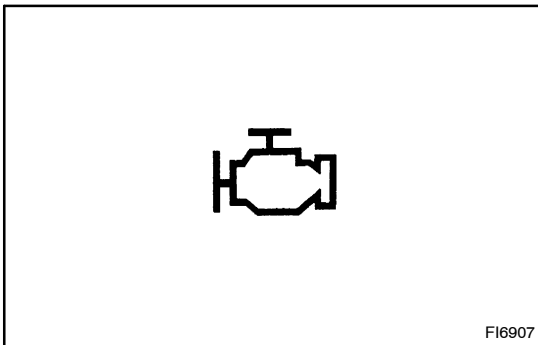

(b) Description for M-OBD

- When troubleshooting Multiplex (M-OBD) vehicles, the only difference from the usual troubleshooting procedure is that you connect the hand-held tester to the vehicle, and read off various data output from the vehicle's Engine & ECT ECU. The vehicle's on-board computer lights up the check engine warning light (CHK(ENG)) on the instrument panel when the computer detects a malfunction in the computer itself or in drive system components. In addition to the CHK ENG lighting up when a malfunction is detected, the applicable DTCs are recorded in the Engine & ECT ECU memory. (See page DI-184).
If the malfunction only occurs in 3 trips, the CHK ENG goes off but the DTCs remain recorded in the Engine & ECT ECU memory.

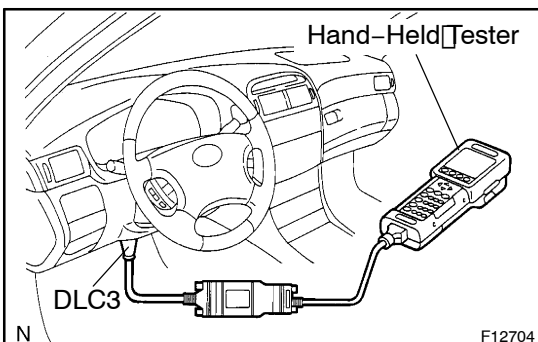

- To check the DTCs, connect a hand-held tester to DLC3 on the vehicle or read the number of blinks of the CHK ENG when TC and CG terminals on the DLC3 are connected. The hand-held tester also enables you to erase the DTCs and activate the several actuators and check freeze frame data and various forms of engine data (For instruction book).

- The diagnosis system operates in normal mode during normal vehicle use, and also has a check (test) mode for technicians to simulate malfunction symptoms and perform troubleshooting. Most DTCs use 2-trip detection logic (*) to prevent erroneous detection and ensure thorough malfunction detection. By switching the Engine & ECT ECU to check (test) mode using hand-held tester when troubleshooting, the technician can cause the CHK ENG to light up for a malfunction that is only detected once or momentarily.
- *2-trip detection logic:
When a logic malfunction is first detected, the malfunction is temporarily stored in the Engine & ECT ECU memory.
If the same malfunction is detected again during the 2nd test drive, this 2nd detection causes the CHK ENG to light up.

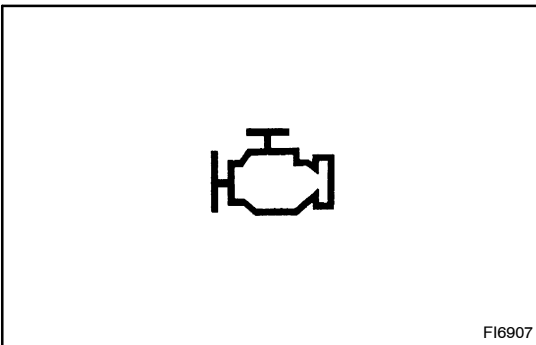

2. INSPECT DIAGNOSIS (NORMAL MODE)

(a) Check the CHK ENG.

- (1) The CHK ENG comes on when the ignition switch is turned ON and the engine is not running.

HINT:

If the CHK ENG does not light up, troubleshoot the combination meter (See page BE-14).

- (2) When the engine is started, the CHK ENG should go off. If the light remains on, the diagnosis system has detected a malfunction or abnormality in the system.

(b) Check the DTC (Using hand-held tester).

NOTICE:

When the diagnostic system is switched from normal mode to check (test) mode, it erases all DTCs and freeze frame data recorded in normal mode. So before switching modes, always check the DTCs and freeze frame data, and note them down.

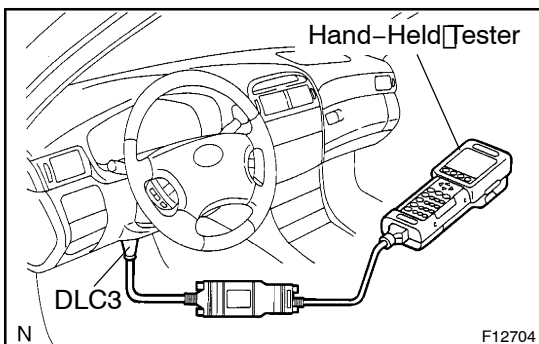

- (1) Prepare hand-held tester.
- (2) Connect the hand-held tester to DLC3 at the lower part of the instrument panel.
- (3) Turn the ignition switch ON and turn the hand-held tester switch ON.
- (4) Use the hand-held tester to check the DTCs and instructions, see the hand-held tester instruction book.
- (5) See page DI-170 to confirm the details of the DTCs.

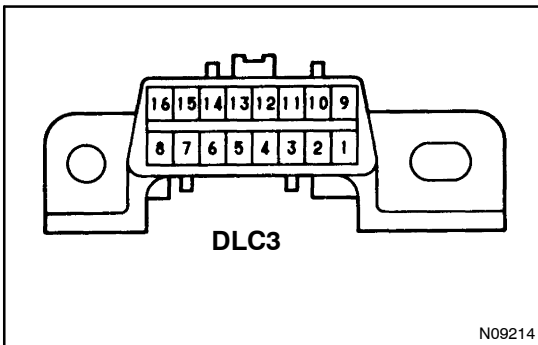

- (c) M-OBD only:
Check the DTC (Not using hand-held tester).
- (1) Turn the ignition switch ON, but do not start the engine.
 - (2) Using SST, connect terminals 13 (TC) and 4 (CG) of DLC3.

SST 09843-18040

- (3) Read the DTC indicated by the number of times the CHK ENG blinks.

HINT:

If the system is operating normally, the light will blink 2 times per second.

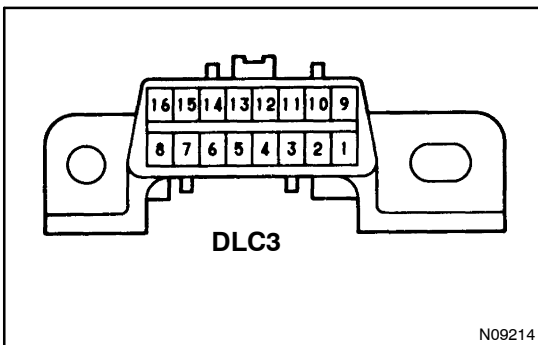
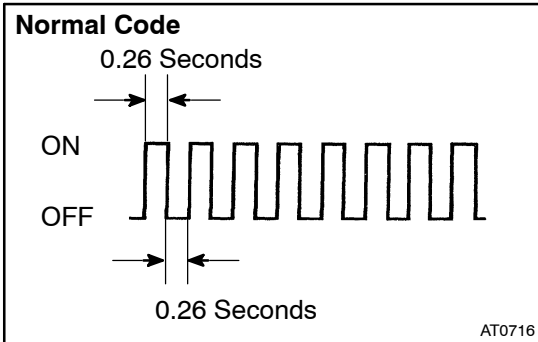

- (d) Inspect the DLC3.
- (1) The vehicle's Engine & ECT ECU uses ISO 9141-2 (Euro-OBD)/ISO 14230 (M-OBD) for communication. The terminal arrangement of DLC3 complies with SAE J1962 and matches the ISO 9141-2/ISO 14230 format.

Terminal No.	Connection/Voltage or Resistance	Condition
7	Bus ⊕ Line/Pulse generation	During transmission
4	Chassis Ground ↔ Body Ground/1 Ω or less	Always
16	Battery Positive ↔ Body Ground/9 - 14 V	Always

HINT:

Only for Euro-OBD:

If your display shows "UNABLE TO CONNECT TO VEHICLE" when you have connected the cable of the OBD scan tool or hand-held tester to DLC3, turned the ignition switch ON and operated the scan tool, there is a problem on the vehicle side or tool side.

- If communication is normal when the tool is connected to another vehicle, inspect DLC3 on the original vehicle.
- If communication is still not possible when the tool is connected to another vehicle, the problem is probably in the tool itself, so consult the Service Department listed in the tool's instruction manual.

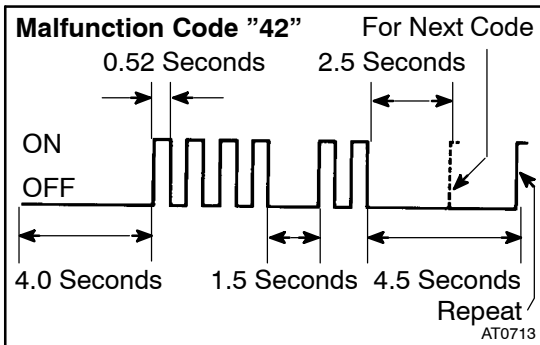

- (2) The malfunction code is indicated, as shown in the chart on the left (DTC "42" is shown as an example).

HINT:

When 2 or more malfunction codes are stored in memory, the lower-numbered code is displayed first.

3. INSPECT DIAGNOSIS (CHECK MODE)**HINT:**

Hand-held tester only: Compared to the Normal mode, the Check mode has high sensing ability to detect malfunctions. Furthermore, the same diagnostic items which are detected in normal mode can also be detected in Check mode.

- (a) Check the DTC.

- (1) Check the initial conditions.
 - Battery positive voltage 11 V or more
 - Throttle valve fully closed
 - Transmission in P range
 - Air conditioning switched off

- (2) Turn the ignition switch OFF.

- (3) Prepare a hand-held tester.

- (4) Connect the hand-held tester to DLC3 at the lower part of the instrument panel.

- (5) Turn the ignition switch ON and switch the hand-held tester ON.

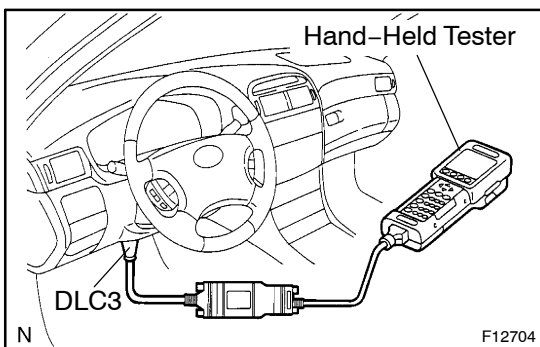

- (6) Switch the hand-held tester from Normal mode to Check mode (Check that the CHK ENG flashes).

- (7) Start the engine (CHK ENG goes out after the engine starts).

- (8) Simulate the conditions of the malfunction described by the customer.

NOTICE:

Leave the ignition switch ON until you have checked the DTCs, etc.

- (9) After simulating the malfunction conditions, use the hand-held tester diagnosis selector to check the DTCs and freeze frame data, etc.

HINT:

Take care not to turn the ignition switch OFF, as turning it off switches the diagnosis system from Check mode to Normal mode, all DTCs etc. are erased.

- (10) After checking the DTC, inspect the applicable circuit.

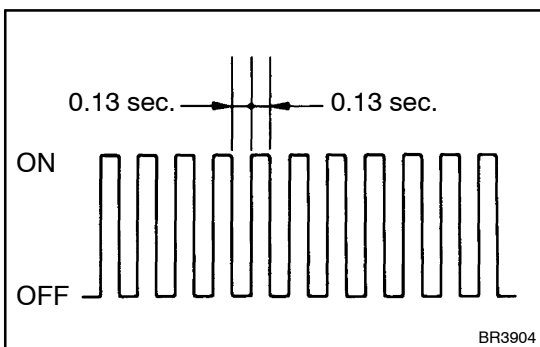

- (b) When using hand-held tester:
Clear the DTC.
The following actions will erase the DTC and freeze frame data. Operate a hand-held tester to erase the codes.
- (c) When not using hand-held tester:
Clear the DTC.
Disconnecting the battery terminals or EFI fuse for 10 seconds or more.

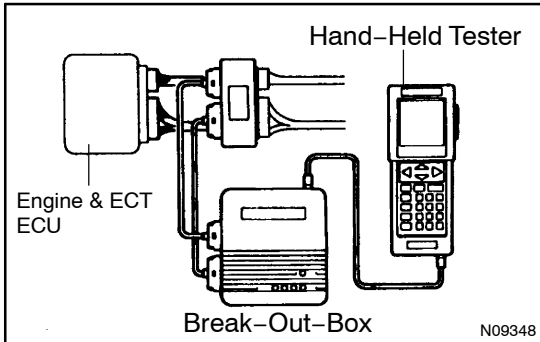

4. ENGINE & ECT ECU OR ECT ECU STANDARD VALUES MEASUREMENT USING BREAK-OUT-BOX AND HAND-HELD TESTER

- (a) Hook up the break-out-box and hand-held tester to the vehicle.
- (b) Read the Engine & ECT ECU input/output values by following the prompts on the tester screen.

HINT:

- Hand-held tester has "Snapshot" function. This records the measured values and is effective in the diagnosis of intermittent problems.
- Please refer to the hand-held tester/break-out-box operator's manual for further details.

5. PROBLEM SYMPTOM CONFIRMATION

Taking into consideration the results of the customer problem analysis, try to reproduce the symptoms of the trouble. If the problem is that the transmission does not shift up, shift down, or the shift point is too high or too low conduct the following road test referring to the automatic shift schedule and simulate the problem symptoms.

6. ROAD TEST

NOTICE:

Conduct the test at normal operating ATF temperature 50 – 80 °C (122 – 176 °F).

(a) D range test (NORM and PWR pattern):

Shift into the D range and fully depress the accelerator pedal and check the following points.

(1) Check up-shift operation.

Check to see that 1 → 2, 2 → 3, 3 → 4 and 4 → 5 up-shift takes place, and that the shift points conform to the automatic shift schedule (See page SS-23).

HINT:

- 5th Gear Up-shift Prohibition Control (1. Coolant temp. is 55 °C (128 °F) or less. 2. Vehicle speed is 51 km/h (32 mph) or less.)
 - 5th Gear Lock-up Prohibition Control (1. Brake pedal is depressed. 2. Coolant temp. is 60 °C (140 °F) or less.)
- (2) Check for shift shock and slip.
Check for shock and slip at the 1 → 2, 2 → 3, 3 → 4 and 4 → 5 up-shifts.
- (3) Check for abnormal noises and vibration.
Run at the D range lock-up or 5th gear and check for abnormal noises and vibration.

HINT:

The check for the cause of abnormal noises and vibration must be done very thoroughly as it could also be due to loss of balance in the differential, torque converter, etc.

(4) Check kick-down operation.

While running in the D range, 2nd, 3rd and 5th gears, check to see that the possible kick-down vehicle speed limits for 2 → 1, 3 → 2, 4 → 3 and 5 → 4 kick-downs conform to those indicated in the automatic shift schedule (See page SS-23).

(5) Check abnormal shock and slip at kick-down.

(6) Check the lock-up mechanism.

- Drive in D range, 5th gear, at a steady speed (lock-up DN) of about 70 km/h (43 mph).
- Lightly depress the accelerator pedal and check that the engine speed does not change abruptly.

If there is a big jump in engine speed, there is no lock-up.

(b) 4 range test:

Shift into the 4 range and fully depress the accelerator pedal and check the following points.

(1) Check up-shift operation.

Check to see that the 1 → 2, 2 → 3 and 3 → 4 up-shift takes place and that the shift point conforms to the automatic shift schedule (See page SS-23).

HINT:

There is no 5th up-shift in the 4 range.

(2) Check engine braking.

While running in the 4 range and 4th gear, release the accelerator pedal and check the engine braking effect.

(3) Check for abnormal noises during acceleration and deceleration, and for shock at up-shift and down-shift.

(c) 3 range test:

Shift into the 3 range and fully depress the accelerator pedal and check the following points.

(1) Check up-shift operation.

Check to see that the 1 → 2 and 2 → 3 up-shift takes place and that the shift point conforms to the automatic shift schedule (See page SS-23).

(2) Check engine braking.

While running in the 3 range and 3rd gear, release the accelerator pedal and check the engine braking effect.

- (3) Check for abnormal noises during acceleration and deceleration, and for shock at up-shift and down-shift.
- (d) 2 range test:
Shift into the 2 range and fully depress the accelerator pedal and check the following points.
- (1) Check up-shift operation.
Check to see that the 1 → 2 up-shift takes place and that the shift point conforms to the automatic shift schedule (See page SS-23).
- (2) Check engine braking.
While running in the 2 range and 2nd gear, release the accelerator pedal and check the engine braking effect.
- (3) Check for abnormal noises during acceleration and deceleration, and for shock at up-shift and down-shift.
- (e) L range test:
Shift into the L range and fully depress the accelerator pedal and check the following points.
- (1) Check no up-shift.
While running in the L range, check that there is no up-shift to 2nd gear.
- (2) Check engine braking.
While running in the L range, release the accelerator pedal and check the engine braking effect.
- (3) Check for abnormal noises during acceleration and deceleration.
- (f) R range test:
Shift into the R range and fully depress the accelerator pedal and check for slipping.

CAUTION:

Before conducting this test ensure that the test area is free from people and obstruction.

- (g) P range test:
Stop the vehicle on a grade (more than 5°) and after shifting into the P range, release the parking brake. Then, check to see that the parking lock pawl holds the vehicle in place.

7. ACTIVE TEST

You are able to set the A/T gear position as you like by operating each solenoid valve forcibly using hand-held tester.

However, the condition that you can set the gear position differs in the setting gear position, so conduct the ACTIVE TEST following the table below.

No.	Indication Gear Condition	Starting Condition	Canceling Condition
1	1st, 2nd	Vehicle speed: 0 km/h (0 mph)	Vehicle speed: 0 km/h (0 mph)
2	3rd	Vehicle speed: 0 km/h (0 mph) or vehicle running at 4th or 5th gear	Vehicle speed: less than 50 km/h (31 mph)
3	4th	<ul style="list-style-type: none"> Vehicle running at 3rd or 5th gear Vehicle speed: 50 km/h (31 mph) 	Vehicle speed: less than 50 km/h (31 mph)
4	5th	<ul style="list-style-type: none"> Vehicle speed: more than 60 km/h (37 mph) Vehicle running at 4th gear Throttle valve opening angle: less than 50 % 	<ul style="list-style-type: none"> Vehicle speed: less than 60 km/h (37 mph) Throttle valve opening angle: more than 50 %

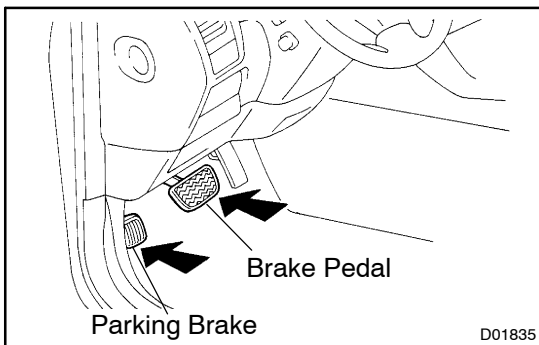

8. BASIC INSPECTION

(a) Check the fluid level.

HINT:

Drive the vehicle so that the engine and transmission are at normal operating temperature.

Fluid temperature: 70 - 80 °C (158 - 176 °F)

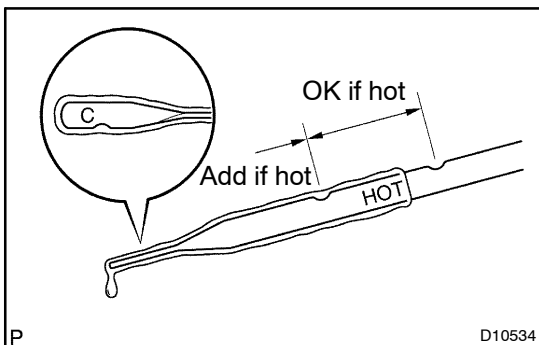

- (1) Park the vehicle on a level surface and set the parking brake.
- (2) With the engine idling and the brake pedal depressed, shift the shift lever into all ranges from P to L range and return to P range.
- (3) Pull out the dipstick and wipe it clean.
- (4) Push it back fully into the pipe.
- (5) Pull it out and check that the fluid level is in the HOT range.

If the level is not within the range, add new fluid.

Fluid type: ATF TYPE T-IV

NOTICE:

Do not overfill.

(b) Check the fluid condition.

If the fluid smells burnt or is black, replace it.

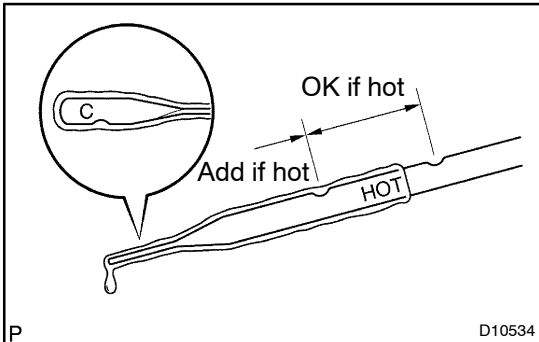
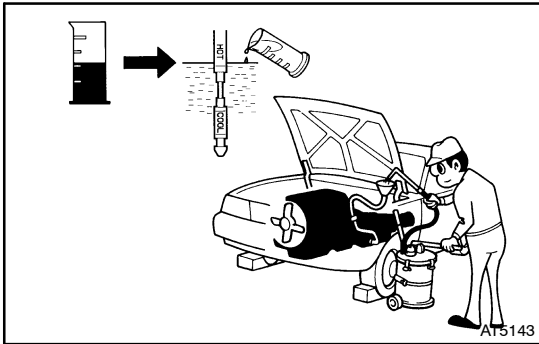

- (c) Replace the ATF.
- (1) Remove the drain plug and drain the fluid.
 - (2) Reinstall the drain plug securely.
 - (3) With the engine OFF add new fluid through the oil filler pipe.

Fluid type: ATF TYPE T-IV

Capacity: 1.8 liters (1.9 US qts, 1.6 Imp.qts)

- (4) Start the engine and shift the shift lever into all ranges from P to L range and then shift into P range.
- (5) With the engine idling, check the fluid level. Add fluid up to the COOL level on the dipstick.
- (6) Check the fluid level at the normal operating temperature, 70 – 80 °C (158 – 176 °F), and add as necessary.

NOTICE:

Do not overfill.

- (d) Check the fluid leaks.

Check for leaks in the transmission.

If there are leaks, it is necessary to repair or replace O-rings, FIPGs, oil seals, plugs or other parts.

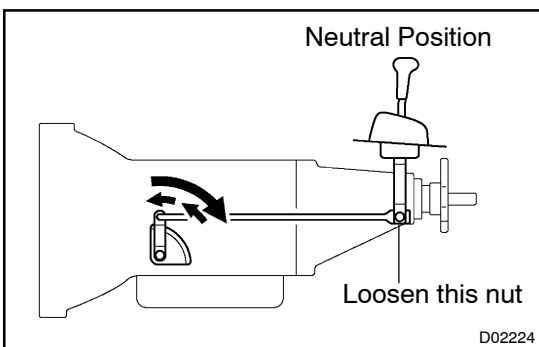

- (e) Inspect and adjust the shift lever position.
- When shifting the shift lever from the N range to other ranges, check that the lever can be shifted smoothly and accurately to each range and that the position indicator is not aligned with the correct position.

If the indicator is not aligned with the correct position, carry out the following adjustment procedures.

- Loosen the nut on the shift lever.
- Push the control shaft fully rearward.
- Return the control shaft lever 2 notches to N range.
- Set the shift lever to N range.
- While holding the shift lever lightly toward the R range side, tighten the shift lever nut.

Torque: 13 N·m (130 kgf·cm, 9 ft·lbf)

- Start the engine and make sure that the vehicle moves forward when shifting the lever from the N to D range and reverses when shifting it to the R range.

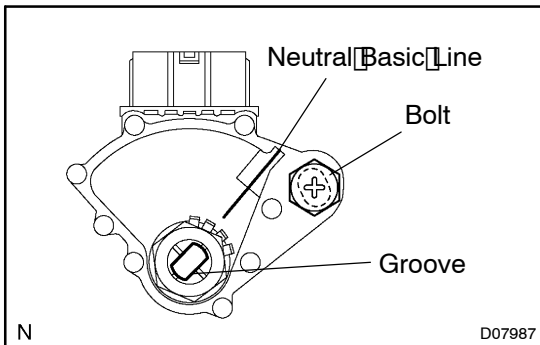

(f) Inspect and adjust the neutral start switch. Check that the engine can be started with the shift lever only in the N or P range, but not in other ranges. If it is not as stated above, carry out the following adjustment procedures.

- Loosen the neutral start switch bolt and set the shift lever to the N range.
- Align the groove and neutral basic line.
- Hold the switch in position and tighten the bolt.

Torque: 13 N·m (130 kgf·cm, 10 ft·lbf)

- For continuity inspection of the neutral start switch, see page Euro-OBD [DI-230](#) or M-OBD [DI-235](#).

9. MECHANICAL SYSTEM TESTS

(a) Measure the stall speed.

The object of this test is to check the overall performance of the transmission and engine by measuring the stall speeds in the D range.

NOTICE:

- Do the test at normal operating ATF temperature 50 – 80 °C (122 – 176 °F).
- Do not continuously run this test for longer than 5 seconds.
- To ensure safety, do this test in a wide, clear level area which provides good traction.
- The stall test should always be carried out in pairs. One technician should observe the conditions of wheels or wheel stoppers outside the vehicle while the other is doing the test.

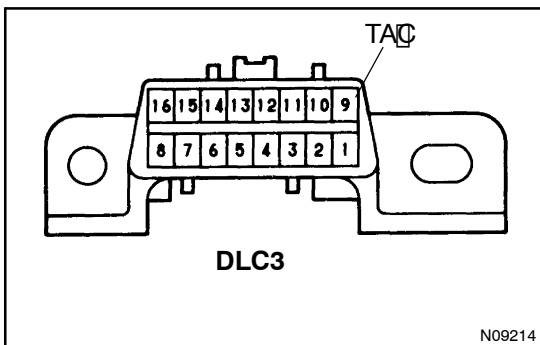

- Chock the 2 wheels.
- Connect a hand-held tester to DLC3 or tachometer to terminal TAC of DLC3 with SST.

SST 09843-18040

- Fully apply the parking brake.
- Keep your left foot pressing firmly on the brake pedal.
- Start the engine.
- Shift into the D range. Press all the way down on the accelerator pedal with your right foot. Quickly read the stall speed at this time.

Stall speed: 2,450 ± 150 rpm (In D range)

Evaluation:

Problem	Possible cause
(a) Stall speed low in D range	<ul style="list-style-type: none"> • Engine output may be insufficient • Stator one-way clutch is operating properly HINT: If more than 600 rpm below the specified value, the torque converter could be faulty.
(b) Stall speed high in D range	<ul style="list-style-type: none"> • Line pressure too low • Forward clutch slipping • No. 2 one-way clutch not operating properly • O/D one-way clutch not operating properly

(b) Measure the time lag.

When the shift lever is shifted while the engine is idling, there will be a certain time lapse or lag before the shock can be felt. This is used for checking the condition of the O/D direct clutch, forward clutch, and 1st & reverse brake.

NOTICE:

- **Do the test at normal operating ATF temperature 50 – 80 °C (122 – 176 °F).**
- **Be sure to allow 1 minute interval between tests.**
- **Take 3 measurements and take the average value.**

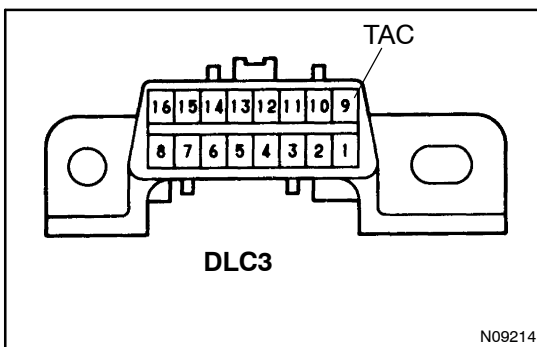

- Chock the 4 wheels.
- Connect a hand-held tester to DLC3 or tachometer to terminal TAC of DLC3 with SST.

SST 09843-18040

- Start engine and check idle speed.

Idle speed: 750 ± 50 rpm (In N range and A/C OFF)

- Shift the lever from N to D range. Using a stop watch, measure the time from when the lever is shifted until the shock is felt.

Time lag: N → D less than 1.2 seconds

- In the same way, measure the time lag for N → R.

Time lag: N → R less than 1.5 seconds**Evaluation (If N → D or N → R time lag is longer than the specified):**

Problem	Possible cause
N → D time lag is longer	<ul style="list-style-type: none"> • Line pressure too low • Forward clutch worn • O/D one-way clutch not operating properly
N → R time lag is longer	<ul style="list-style-type: none"> • Line pressure too low • Direct clutch worn • 1st & reverse brake worn • O/D one-way clutch not operating properly

10. HYDRAULIC TEST

Measure the line pressure.

NOTICE:

- Do the test at normal operation ATF temperature 50 – 80 °C (122 – 176 °F).
 - The line pressure test should always be carried out in pairs. One technician should observe the conditions of wheels or wheel stopper outside the vehicle while the other is doing the test.
 - Be careful to prevent SST's hose from interfering with the exhaust pipe.
 - (1) Warm up the ATF.
 - (2) Remove the test plug on the right side of the transmission case and connect SST (See page AT-34 for the location to connect SST).
- SST 09992-00095 (09992-00231, 09992-00271)
- (3) Fully apply the parking brake and chock the 4 wheels.
 - (4) Connect a hand-held tester to DLC3.
 - (5) Start the engine and check idling speed.
 - (6) Keep your left foot pressing firmly on the brake pedal and shift into D range.
 - (7) Measure the line pressure when the engine is idling.
 - (8) Depress the accelerator pedal all the way down. Quickly read the highest line pressure when engine speed reaches stall speed.
 - (9) In the same way, do the test in R range.

Specified line pressure:

Condition	D range kPa (kgf / cm ² , psi)	R range kPa (kgf / cm ² , psi)
Idling	395 – 455 (4.0 – 4.6, 57 – 65)	0
Stall	1,200 – 1,360 (12.2 – 13.8, 174 – 196)	1,655 – 1,960 (16.9 – 20.0, 240 – 282)

If the measured pressure is not up to the specified value, recheck the throttle cable adjustment and retest.

Evaluation

Problem	Possible cause
If the measured values at all ranges are higher	<ul style="list-style-type: none"> • SLT solenoid valve defective • Regulator valve defective
If the measured values at all ranges are lower	<ul style="list-style-type: none"> • SLT solenoid valve defective • Regulator valve defect • Oil pump defect • O/D direct clutch defect
If pressure is low in the D range only	<ul style="list-style-type: none"> • D range circuit fluid leakage • Forward clutch defect
If pressure is low in the R range only	<ul style="list-style-type: none"> • R range circuit fluid leakage • Direct clutch defect • 1st & reverse brake defect

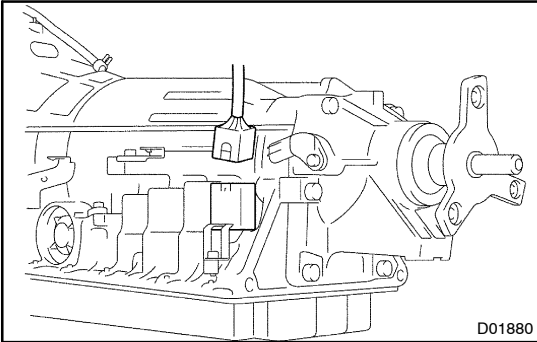

11. MANUAL SHIFTING TEST

HINT:

By this test, it can be determined whether the trouble is within the electrical circuit or is a mechanical problem in the transmission.

- (a) Disconnect the solenoid wire.
- (b) Inspect the manual driving operation.

Check that the shift and gear positions correspond to the table below.

While driving, shift through the L, 2, 3, 4 and D ranges. Check that the gear change corresponds to the shift range.

Shift range	Gear position
D	5th
4	5th
3	4th
2	3rd
L	3rd
R	Reverse
P	Pawl Lock

HINT:

- If the L, 2, 3, 4 and D range gear positions are difficult to distinguish, do the following read test.
- If any abnormality is found in the above test, the problem is in the transmission itself.

- (c) Connect the solenoid wire.
- (d) Cancel out DTC.