

SUSPENSION AND AXLE

■ SUSPENSION

1. General

A newly designed double wishbone type suspension is used for both the front and rear to provide a high level of controllability and riding comfort. In addition to the standard coil spring suspension, an electronically modulated air suspension which uses compressed air to act as a spring is optional equipment.

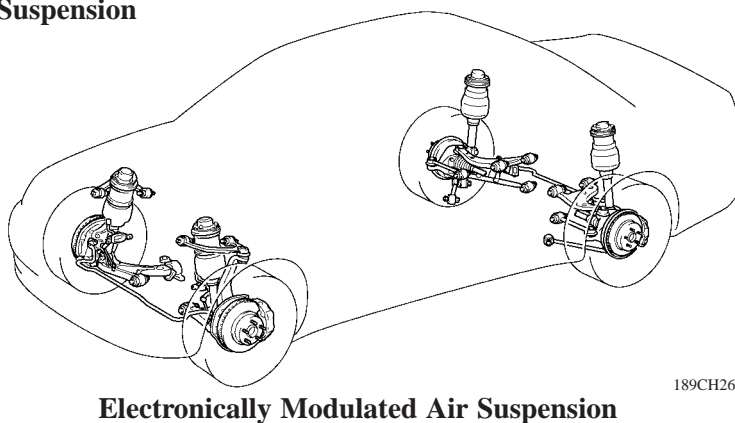
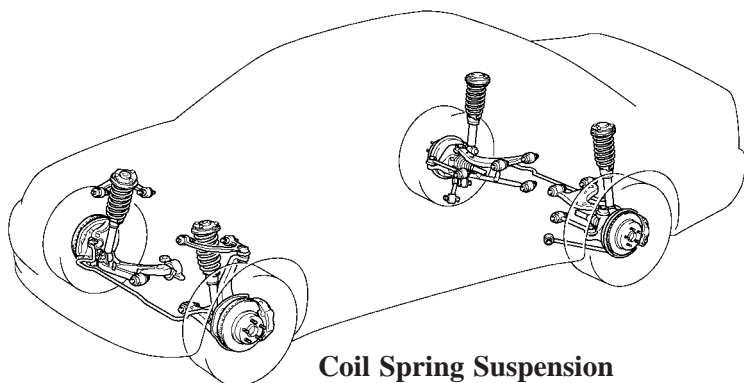

189CH26

► Specifications ◀

| Item | New LS430 | | | | Previous LS400 | | | | |
|---------------------------------------|-----------|----------------|----------------|----------------|----------------|----------------|----------------|----------------|----------------|
| | Front | | Rear | | Front | | Rear | | |
| | Coil | Air | Coil | Air | Coil | Air | Coil | Air | |
| Tread | mm (in.) | 1571 (61.8) | 1573 (61.9) | 1564 (61.6) | 1575 (62.0) | 1570 (61.8) | 1574 (62.0) | 1568 (61.7) | 1574 (62.0) |
| Caster* ¹ | degrees | 6°45' | 7°15' | — | — | 7°00' | 7°25' | — | — |
| Camber* ¹ | degrees | -0°05' | -0°15' | -0°55' | -1°35' | 0°20' | 0°05' | -0°50' | -1°25' |
| Toe-In* ¹ | mm (in.) | 1 (0.04) | ← | 3 (0.12) | ← | 3 (0.12) | 1 (0.04) | 2 (0.08) | 3 (0.12) |
| King Pin Inclination* ¹ | degrees | 9°00' | 9°15' | — | — | 8°25' | 8°40' | — | — |

*1 : Unloaded Vehicle Condition

2. Front Suspension

General

- As in the previous model, a double wishbone type independent suspension is used on the new model.
- The upper arm and steering knuckle made of forged aluminum have been adopted to realize lightweight.
- The power steering gear box has been located forward of the axle so that the wheels can be toe-out in accordance with the lateral force that is applied to the steering during cornering, thus realizing a milder steering response.
- Low-pressure (N₂) gas sealed front shock absorbers with a linear control valve and built-in rebound spring have been adopted to realize both driving stability and riding comfort.
- The suspension geometry suitable to new model has been provided to realize excellent stability, controllability, and riding comfort.

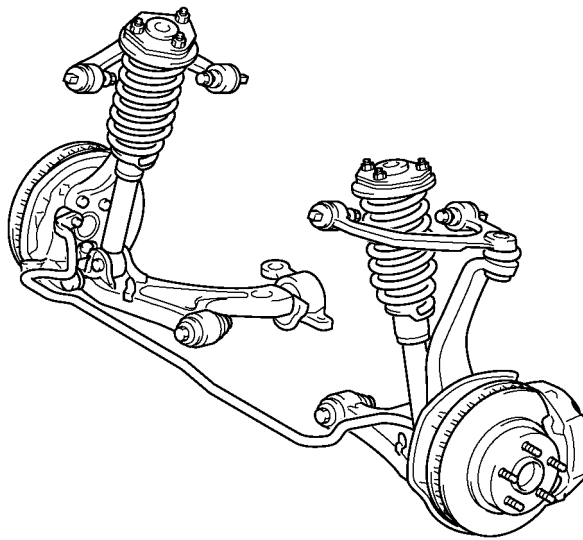

189CH27

CH

Upper Arm

- The upper arm made of forged aluminum has been adopted to realize lightweight.
- The upper arm bushing has been changed from pillow ball bushing to rubber bushing.

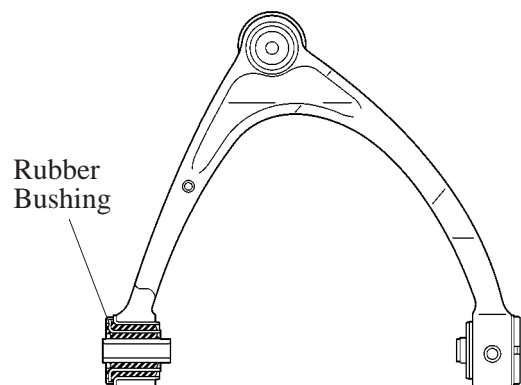

189CH28

Steering Knuckle

The steering knuckle made of stamp-forged aluminum has been adopted to realize lightweight.

Service Tip

Make sure not to allow the insert to slip out when removing the upper arm and the steering knuckle. For details, refer to the LEXUS LS430 Repair Manual (Pub. No. RM792E).

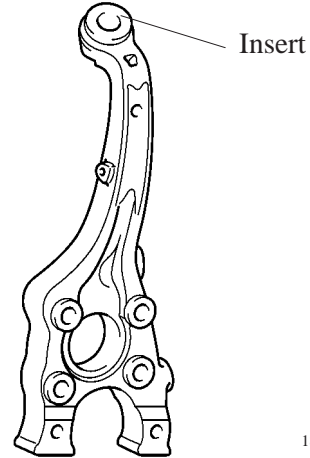

189CH29

Lower Arm

The shape of the lower arm No. 1 bushing and the lower arm bracket bushing has been optimized to improve ride comfort.

Also, lower arm bracket bushing has been adopted the liquid-filled compound bushing.

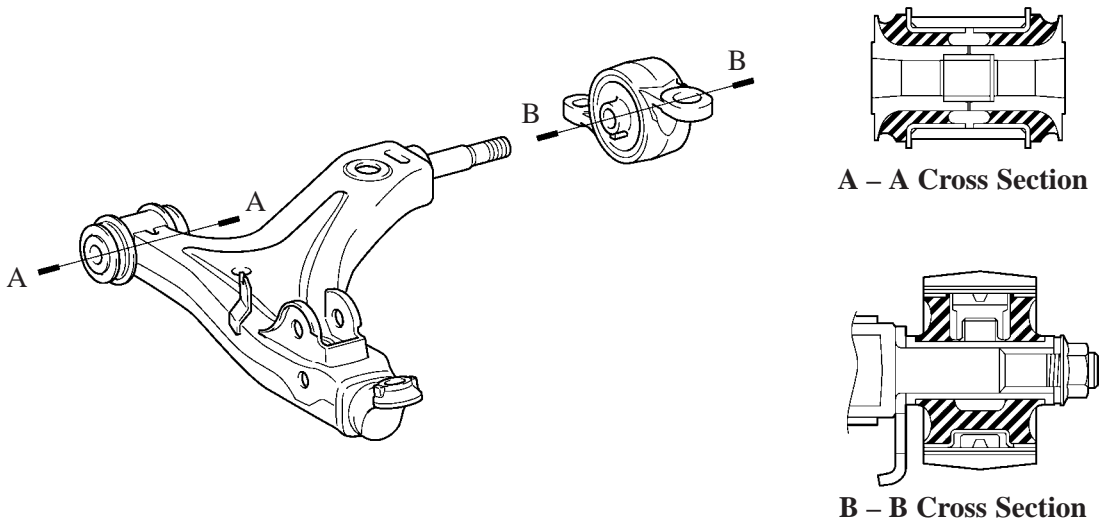

189CH30

Suspension Upper Support and Bound Stopper

As in the previous model, the rubber content of the suspension upper support has been adopted to improve stability, controllability, and riding comfort, to reduce noise and vibration.

Also, the spring bumper has been changed from rubber to urethane to improve ride comfort.

► Characteristics of Grounding Load ◄

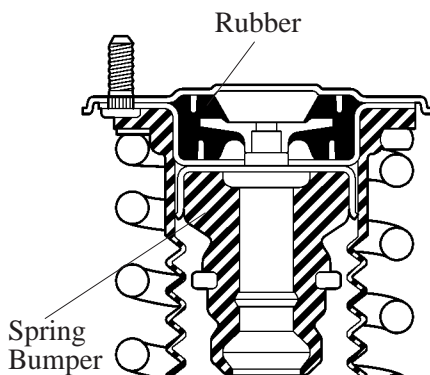

189CH31

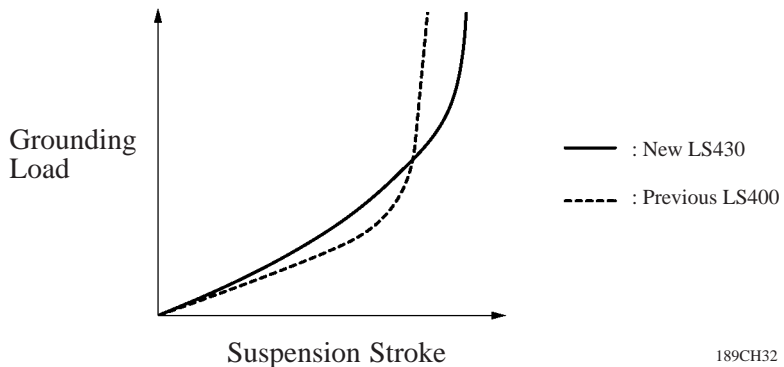

189CH32

Shock Absorber (for Coil Spring Suspension)

1) General

Low-Pressure (N₂) gas sealed front shock absorbers with a linear control valve and built-in rebound spring have been adopted to realize both driving stability and riding comfort.

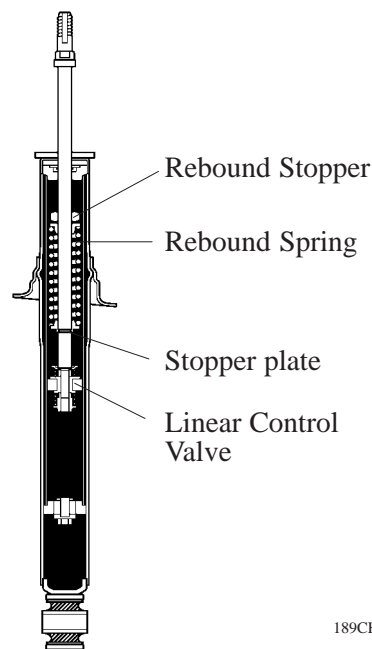

189CH33

2) Linear Control Valve

The linear control valve consists of a C-valve, a cutout valve and a leaf valve.

These valves adopt a laminate construction and form orifice. At low piston speeds, the oil flows through the cutouts of the valves to achieve a linear damping force. At medium and high piston speeds, the valves flex to increase the amount of oil that flows through, thus reducing the damping force.

Through the adoption of the linear control valve, the changes in the damping force are made constant at low piston speeds, thus making the vehicle behave more smoothly in relation to the steering operation. At medium and high piston speeds, the damping force is reduced to lessen the vehicle vibrations in relation to the roughness of the road surface.

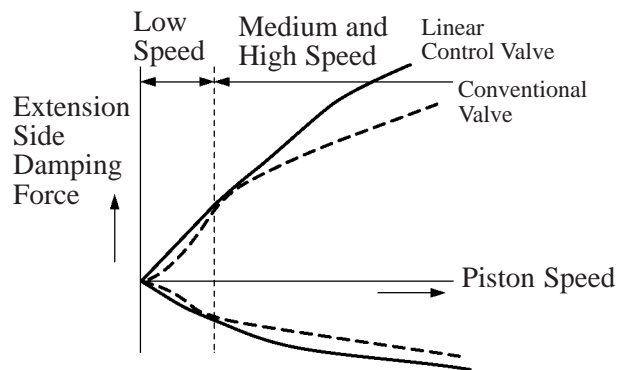

Damping Force Characteristics

189CH95

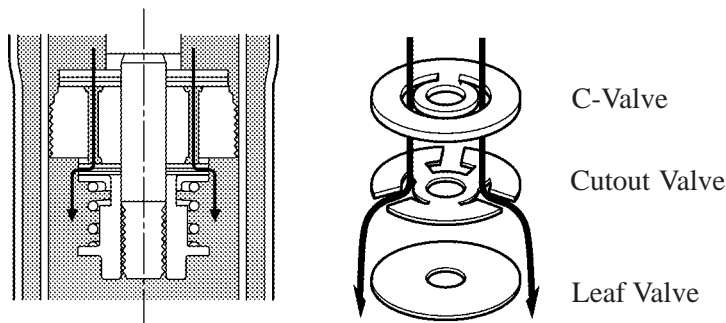

Low Speeds

189CH96

3) Rebound Spring

In the front shock absorber with a built in rebound spring, the function of the rebound spring that is provided in the shock absorber case combines with the function of the coil spring in order to restrain the elongation of the entire suspension during rebounds. Consequently, only the function of the coil spring is applied when the suspension stroke is small during normal driving, in order to realize a soft and comfortable ride. However, when the inner wheel makes large rebounds, such as when the vehicle is cornering, the functions of both the rebound spring and the coil spring are combined in order to reduce the elongation of the entire suspension. As a result, the vehicle's excellent maneuverability and stability have been realized.

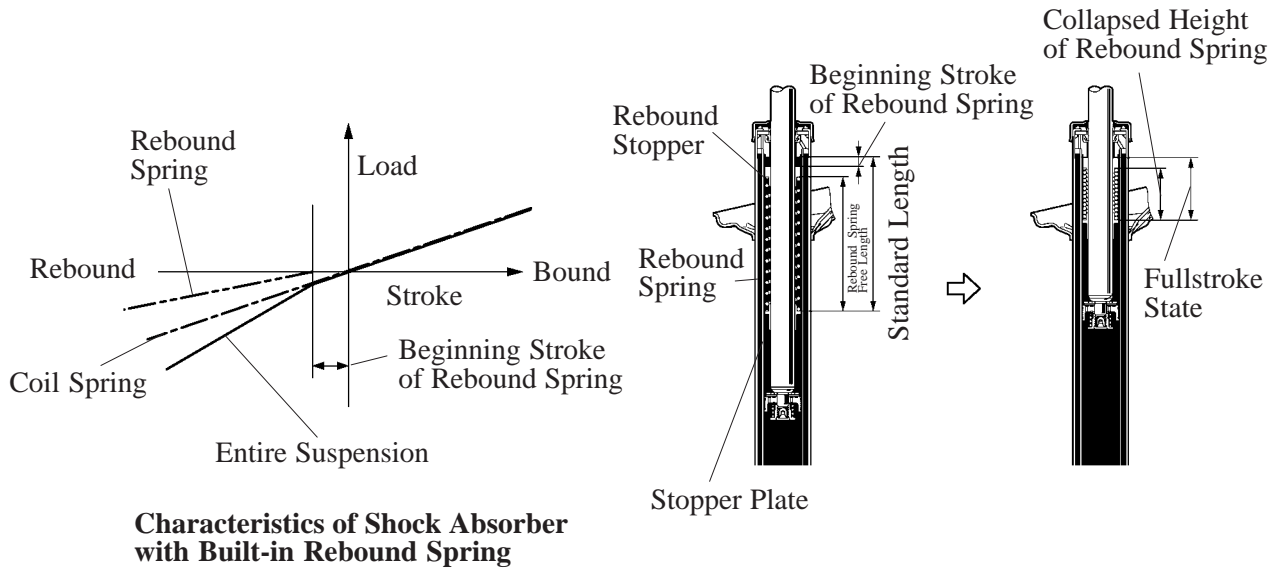

185CH16

185CH17

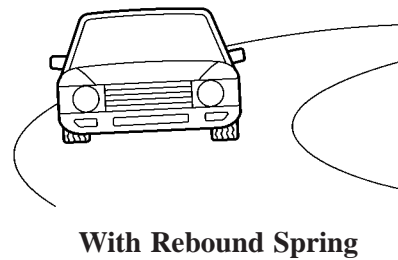
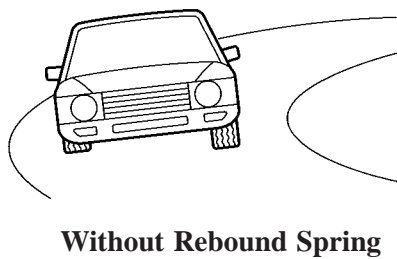

187CH10

3. Rear Suspension

General

- As in the previous model, a double wishbone type independent suspension is used on the new model.
- The upper arm made of forged aluminum and the axle carrier made of aluminum cast have been adopted to realize lightweight.
- The suspension geometry suitable to new model has been provided to realize excellent stability, controllability, and riding comfort.

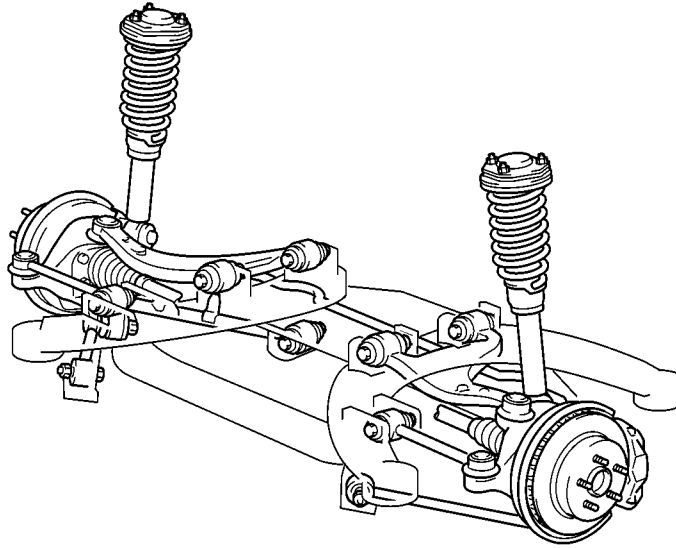

189CH34

CH

Upper Arm

- The upper arm made of forged aluminum has been adopted to realize lightweight.
- The upper arm bushing has been optimized to realize excellent stability, controllability, and ride comfort.

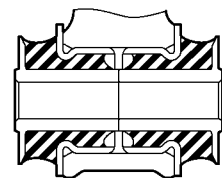
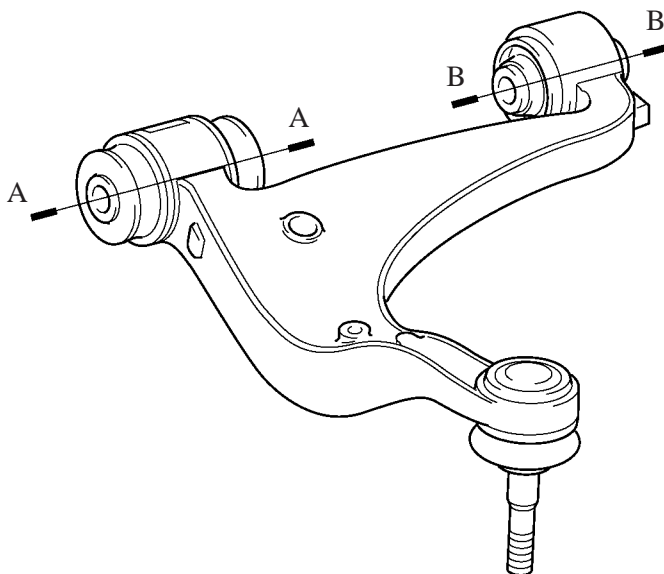

A – A Cross Section

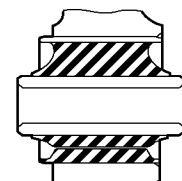

B – B Cross Section

189CH35

Axle Carrier

- The axle carrier made of aluminum cast has been adopted to realize lightweight.
- The axle carrier and the arms are joined with ball joints to realize excellent stability, controllability, and ride comfort.

Service Tip

As with the front steering knuckle, make sure that the insert does not slip out when removing the axle carrier and the arms. For details, refer to the LEXUS LS430 Repair Manual (Pub. No. RM792E).

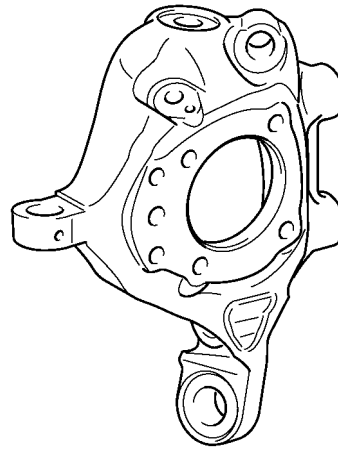

189CH36

4. Electronically Modulated Air Suspension

General

- The electronically modulated air suspension system of the new LS430 is an advancement of the system of the previous LS400. While its basic construction and operation remain the same as that of the previous LS400, it offers the improvements described below. As a result, the effect of the road bumps on the vehicle in various and driving conditions has been minimized and a stable vehicle posture is maintained.
- The semi-active control of the damping force control has been changed from sky-hook control to non-linear H^∞ control in order to effect 4-wheel independent control that constantly achieves an optimal damping force in relation to the bumpiness of the road surface. As a result, excellent ride comfort has been realized.
- Imaginary roll damper control has been adopted for the damping force control to optimize the vehicle roll attitude during cornering. As a result, excellent cornering stability and controllability have been realized.
- Speed sensitive control has been adopted to automatically lower the vehicle height when the vehicle is driven at a prescribed speed or higher, in order to provide the aerodynamics and excellent stability at high speeds.
- The damping mode select switch that selects the shock absorber damping force (“normal” or “sport”) has been newly adopted.
- The construction of the pneumatic cylinder has been optimized to realize excellent stability, controllability, and ride comfort.
- The compressor motor of the height control compressor has been made more compact, and the air filter, which was provided separately on the previous LS400, has also been made more compact and it is now enclosed in the compressor. Furthermore, on the new LS430, a relief valve mechanism has been added to the exhaust valve that is provided on the compressor. As a result, the relief valve that was enclosed in the rear height control valve on the previous LS400 has been discontinued.
- The connector of the air suspension tube has been changed from the clip-and-grommet type that is used on the previous LS400 to the checker type quick joint. As a result, the ease of operation and service has been improved.

Service Tip

Before jacking up the vehicle or raising it on a hoist, make sure that the ignition switch is turned OFF. If the vehicle must be raised with its engine running, jump terminals OPB and SIL of the DLC3 (Data Link Connector 3) to stop the vehicle height control operation of the air suspension ECU.

Layout of Components

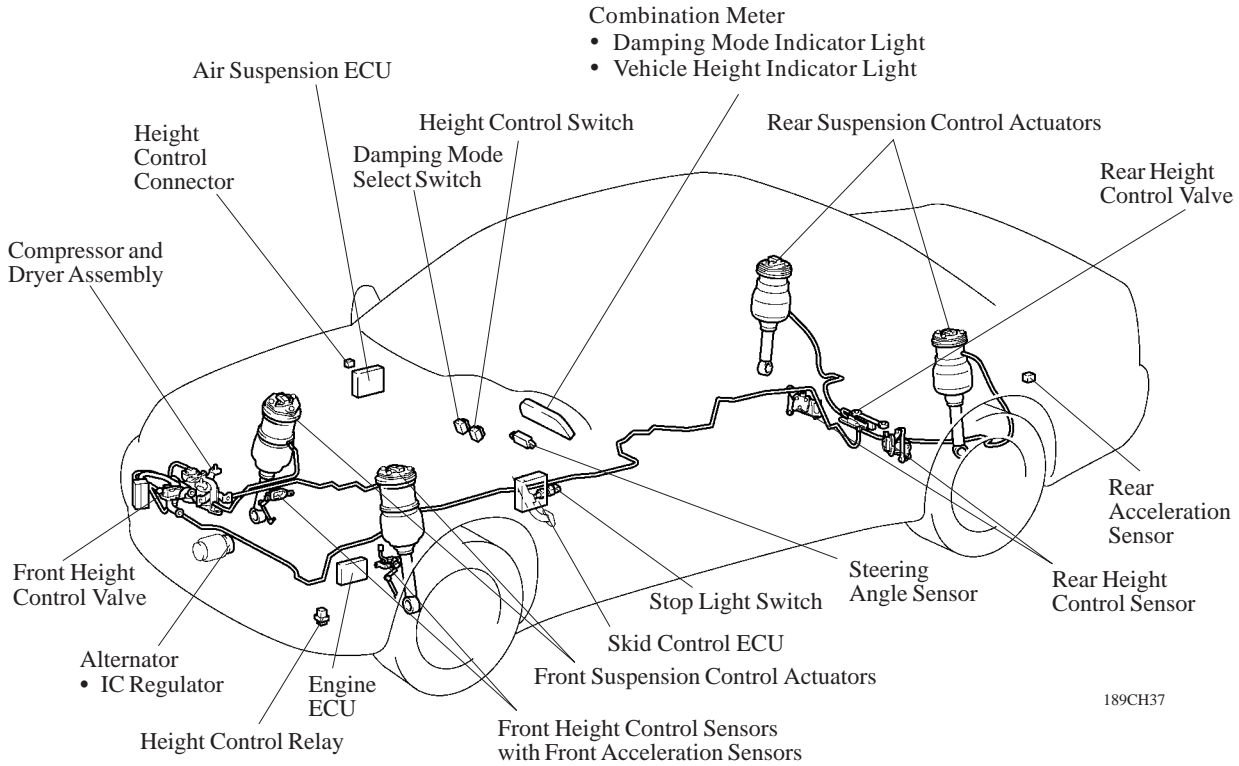

189CH37

System Diagram

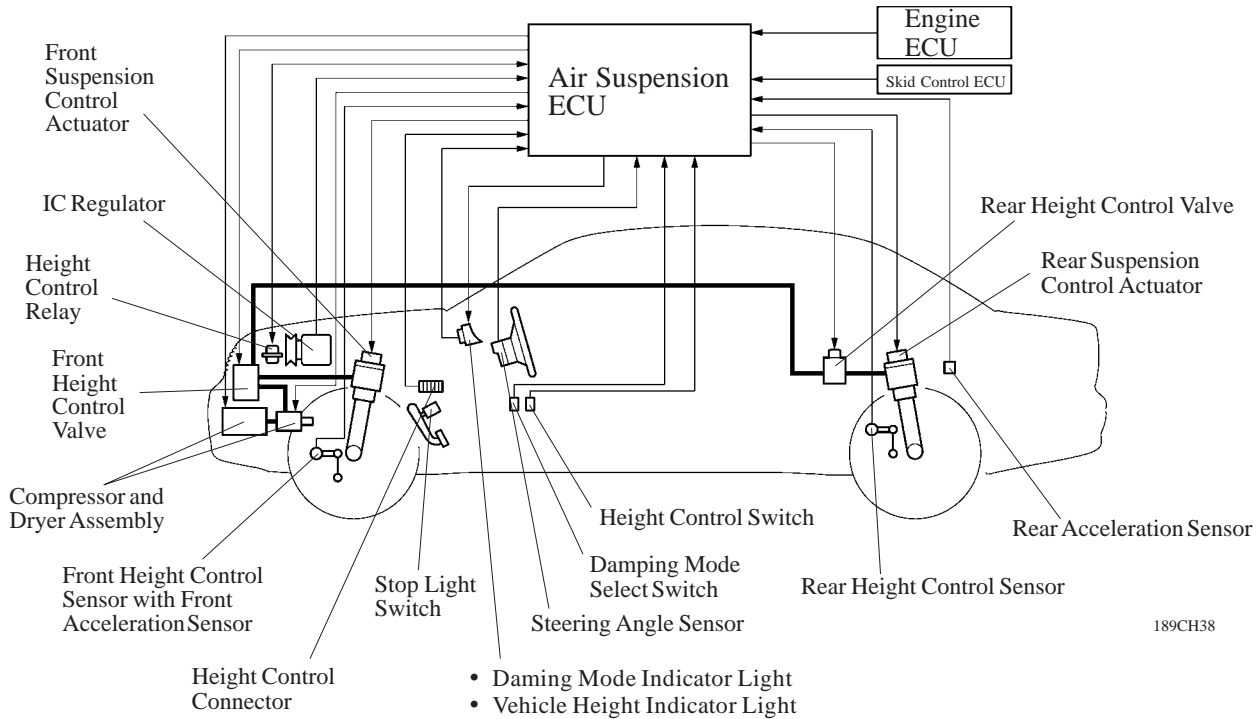

189CH38

Wiring Diagram

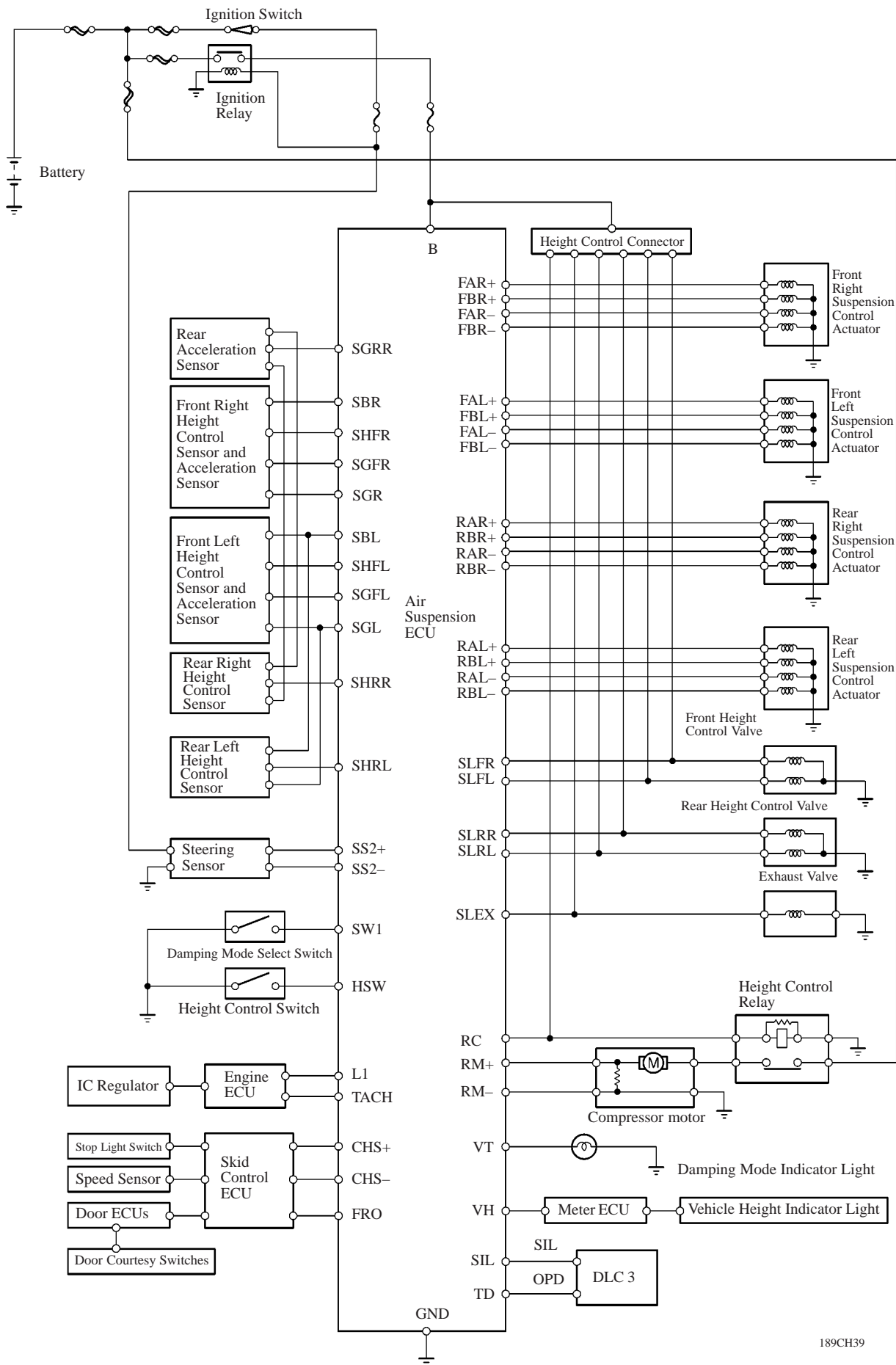

CH

Construction

The configuration of the air suspension control system in the new LS430 is as shown in the following chart.

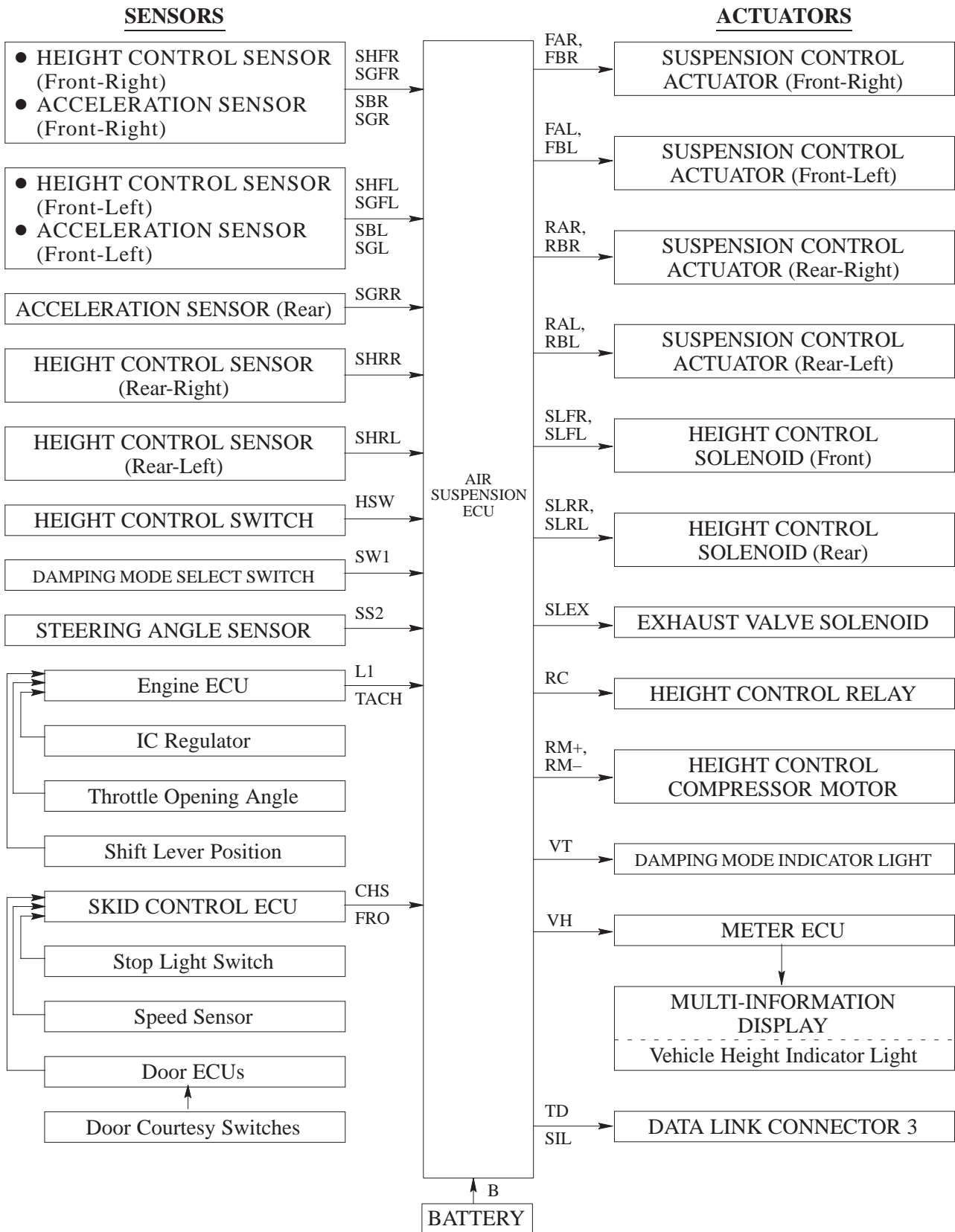

Function of Components

| Component | Function |
|--------------------------------------|---|
| Suspension Control Actuators | Changes the damping force. |
| Height Control Relay | Supplies electricity to the compressor motor. |
| Front and Rear Height Control Valves | Supplies and discharges compressed air to and from air chambers in 4 pneumatic cylinders (front left and right, rear left and right). |
| Height Control Compressor and Motor | Supplies compressed air to increase the vehicle height. |
| Height Control Dryer | Removes moisture from the compressed air. |
| Exhaust Valve | Discharges compressed air to atmosphere from pneumatic cylinders to lower the vehicle. |
| Height Control Sensors | Detects the vehicle height, and displacement volume of the suspension caused by unevenness of the road. |
| Front Acceleration Sensors | Detects the front right and left body vertical accelerated motions. |
| Rear Acceleration Sensor | Detects the rear body vertical accelerated motion. |
| Height Control Connector | By Connecting terminals, adjusts the vehicle height directly without passing through the air suspension ECU. |
| Steering Angle Sensor | Detects the steering direction and angle of the steering wheel. |
| Vehicle Height Indicator Light | Displays on the multi-information display when the height control switch position is on HIGH. |
| Height Control Switch | Selects the vehicle height. |
| Damping Mode Indicator Light | Lights up indicating that damping force are in “sport” mode by the damping mode select switch, and warns that a malfunction has occurred in the suspension control system. |
| Damping Mode Select Switch | Selects the damping force. |
| Skid Control ECU | Receives the signals of the stop light switch, door courtesy switch, and speed sensor, and sends them to the air suspension ECU. |
| Engine ECU | Receives the signals of the throttle opening angle, shift lever position, and IC regulator, and sends them to the air suspension ECU. |
| Air Suspension ECU | <ul style="list-style-type: none"> • Controls the damping force and vehicle height according to the operation modes. • Blinks the damping mode indicator light to warn the driver when the ECU detects a malfunction in the suspension control system. • When changed to the diagnostic mode, indicates any malfunction by DTCs (Diagnosis Trouble Codes). |

Construction and Operation

1) Height Control Sensor

The height control sensors detect the vehicle's height. There are two front height control sensors, one for the right, and the other for the left. They are mounted via the control links to the lower arms of the front suspension and to the body. The front height control sensors are the integrated construction type with a built-in acceleration sensor. There are also two rear height control sensors, for the right and left sides. They are mounted via the control links to the lower arms of the rear suspension and to the body. Through the use of a height control sensor link and shaft, each height control sensor converts the rectilinear movement of the control link into a rotational movement, and the result is detected in the form of a rotational angle. A brush that is integrated with the shaft rotates over a resistor that is formed on the printed circuit board, thus enabling the rotational angle to be detected in the form of voltage. The resistor has adopted a dual construction, and the brush is a scratch wiper brush type that excels in contact resistance stability.

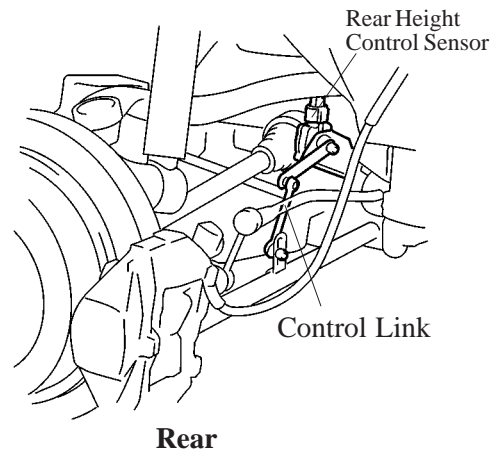
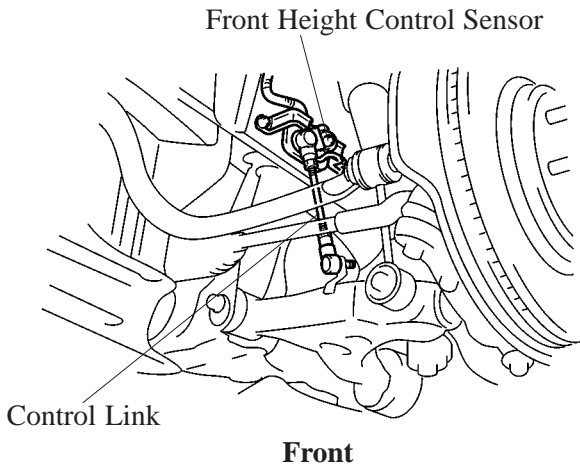

189CH40

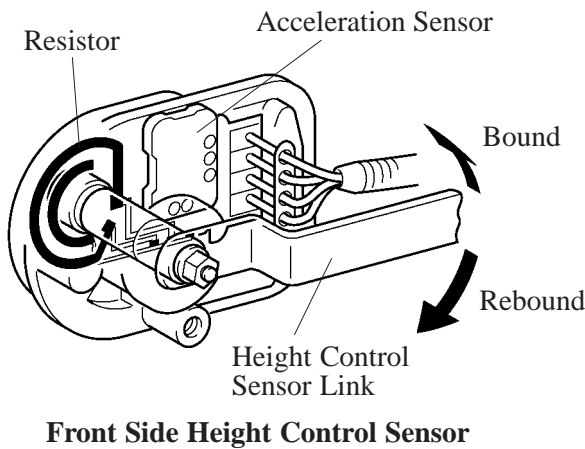

189CH41

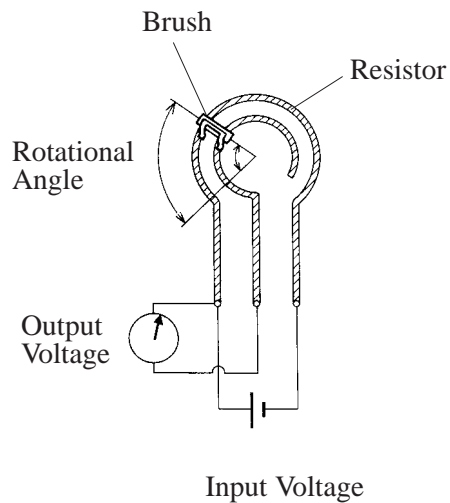

162CH64

Diagram of the Principle

2) Acceleration Sensor

The acceleration sensors detect the vehicle's vertical acceleration. The front acceleration sensor is integrated with the front height control sensor. The rear acceleration sensor is installed in the luggage compartment.

Inside each sensor, 2 piezoelectric ceramic discs are fixed on both sides of a diaphragm which is supported by its center. When acceleration is applied to the entire sensor, the piezoelectric ceramic discs bend from their own weight. As a characteristic of piezoelectric ceramic, they generate electricity in proportion to the rate of their curvature. This is converted, via an electronic circuit, to a voltage in proportion to the acceleration rate and is output to the air suspension ECU.

The air suspension ECU calculates the sprung mass vertical velocity of the 4 wheels according to the signals received from the acceleration sensors. Also, by way of the height control sensors, the air suspension ECU calculates the relative velocity between sprung and unsprung mass. Based on these values, the air suspension ECU controls the damping force for each of the 4 wheels to an optimal level to provide a stable driving posture.

► Sensor Basic Operation ◀

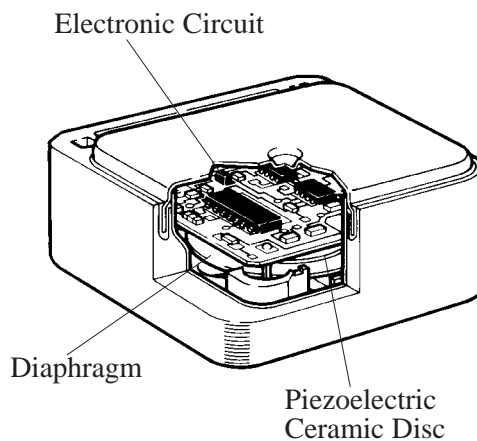

189CH42

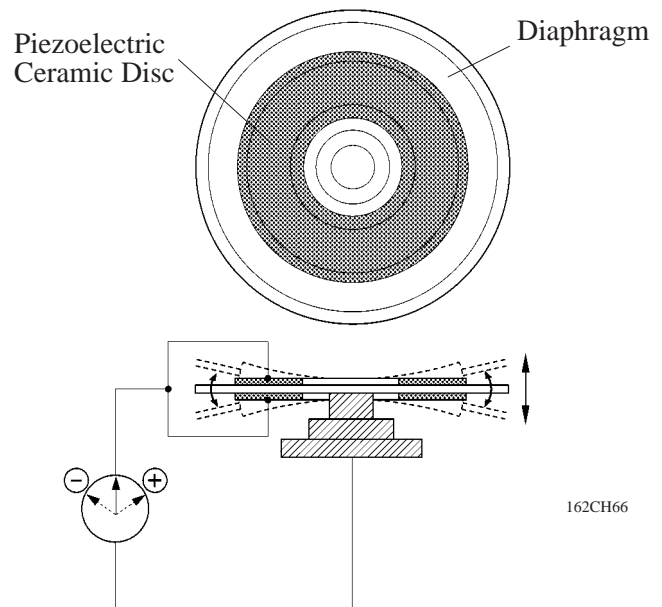

162CH66

3) Steering Angle Sensor

The steering angle sensor is fitted to the turn signal switch assembly and detects the steering direction and angle.

The sensor contains 2 photo interrupters with phases, and a slotted disc interrupts the light to turn the photo transistor ON and OFF to detect the steering direction and angle.

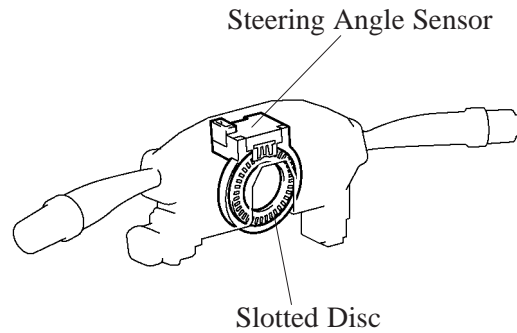

189CH43

4) Height Control Valve

The height control valves control the air passage between the compressor and the 4 pneumatic cylinders. Two height control valves are provided, one for the front and the other for the rear.

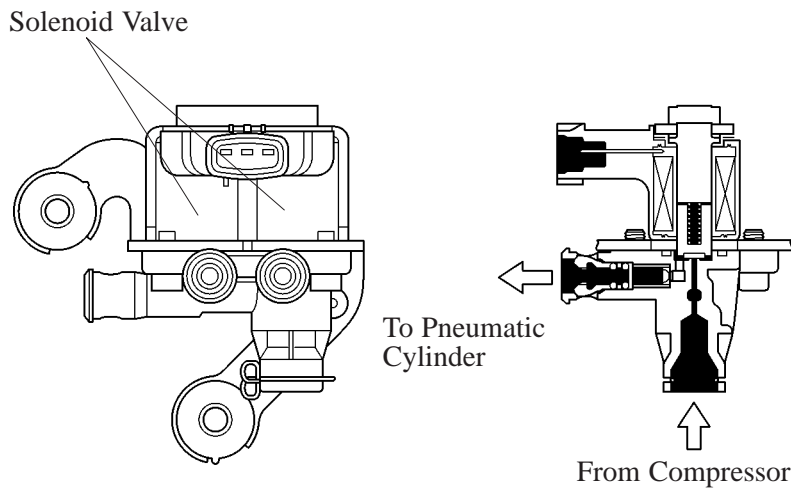

189CH44

5) Compressor and Dryer Assembly

The compressor and dryer assembly has an integral construction with the compressor and motor to make the compressed air necessary for raising the vehicle height, the dryer to eliminate the moisture in the compressed air made by the compressor, and the exhaust valve to drain the compressed air out to the atmosphere from the pneumatic cylinders.

On the previous LS400, the air filter has been made more compact and it is enclosed in the compressor.

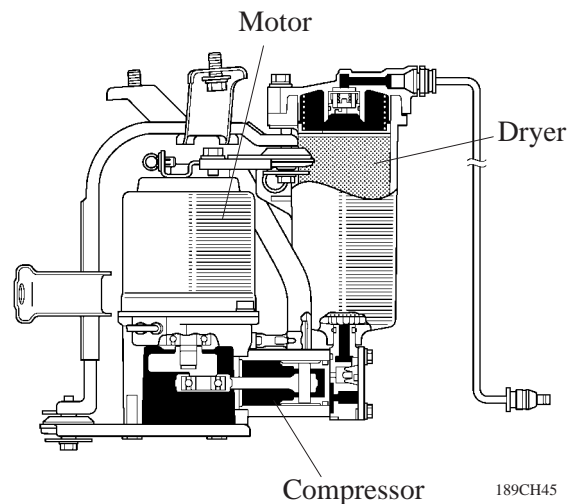

189CH45

6) Pneumatic Cylinder with Shock Absorber

Each pneumatic cylinder consists of a variable damping force shock absorber containing low-pressure nitrogen gas and a single type air chamber with a large compressed air capacity in order to realize excellent riding comfort. To switch the shock absorber's damping force, a hard damping valve and a soft damping valve have been provided. The damping force is varied by the rotary valve, which changes the ratio of oil that passes through the valve.

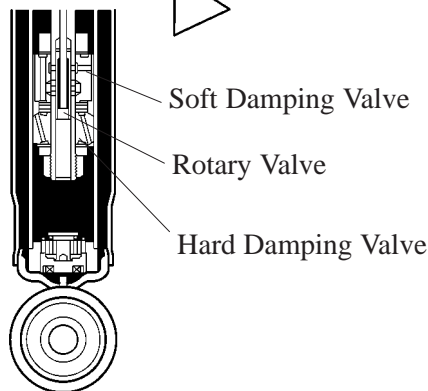
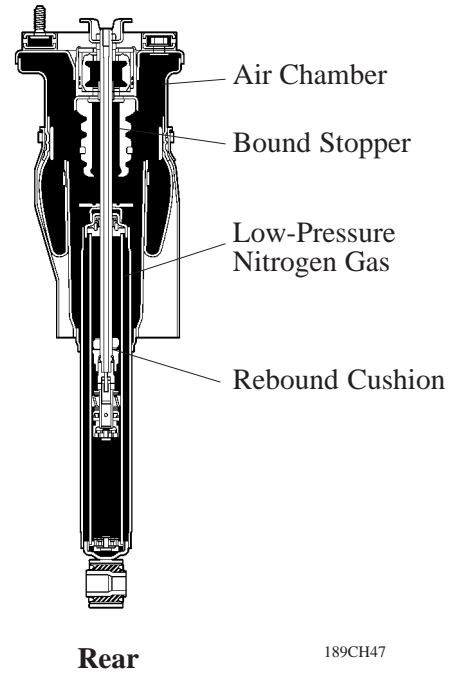
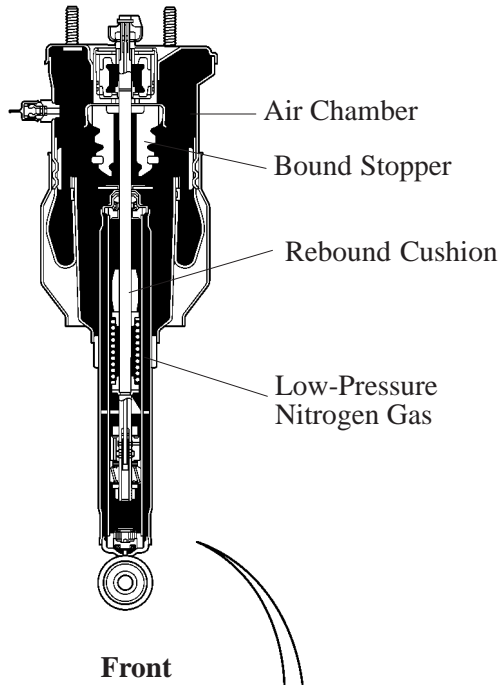

189CH46

189CH47

7) Suspension Control Actuator

The suspension control actuator is located at the top of each pneumatic cylinder. This actuator uses a step motor that switches in 9 steps to effect minute changes in the damping force. The step motor consists of 2 sets of stators and coils. To control the damping force, the step motor causes the magnetic rotor, which is directly coupled to the shock absorber control rod, to make small rotational movements in accordance with the signals received from the air suspension ECU.

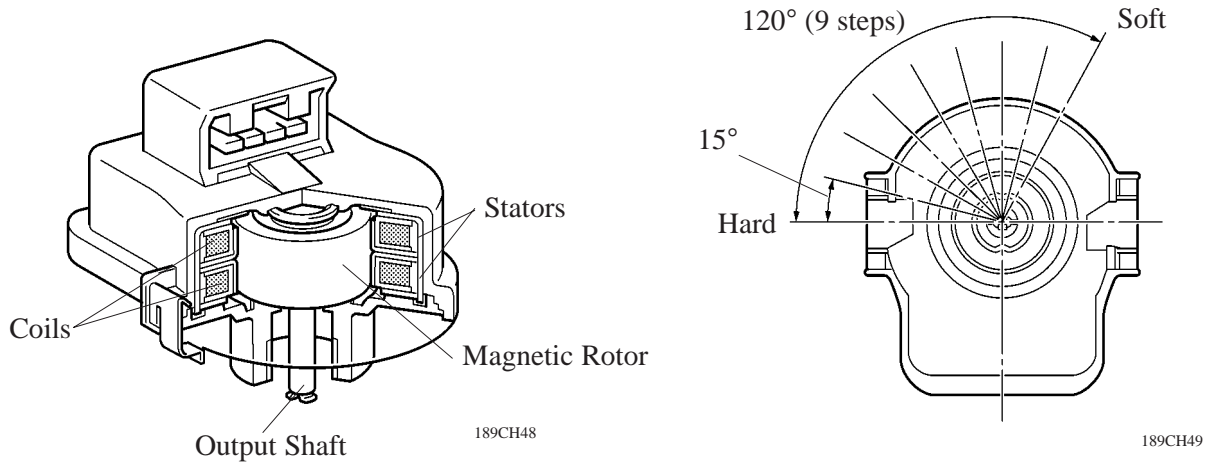

8) Quick Connector

The connector of the air suspension tube has been changed from the clip-and-grommet type that is used on the previous LS400 to the checker type quick joint. As a result, the ease of operation and service has been improved.

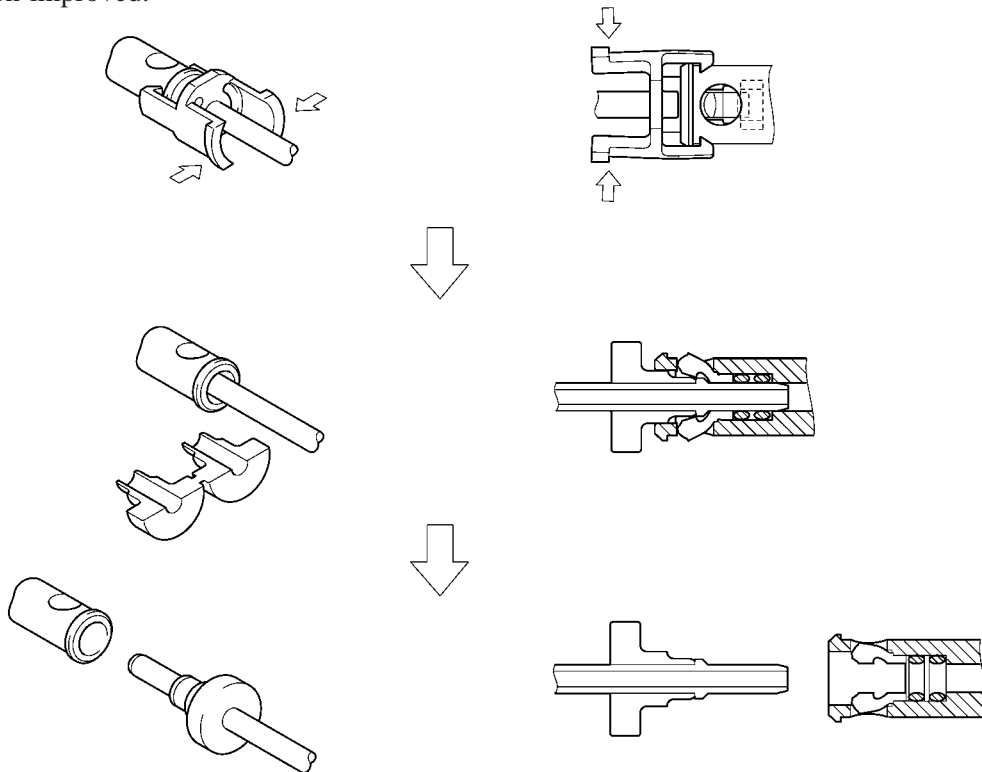

189CH50

Service Tip

If the air suspension tube is removed, the O-ring, height control tube plate, and No. 2 height control tube connector cannot be reused.

Air Suspension ECU

1) General

The air suspension control system of new LS430 and previous LS400 are compared below.

► Damping Force Control ◀

| Control | Function | New LS430 | Previous LS400 |
|---|---|-----------|----------------|
| Semi-Active Control (Non-Linear H^∞ Control) | Smoothly changes the damping force to a target value in accordance with the changes in the road surface or driving conditions. Thus, excellent ride comfort has been realized while ensuring a level of vibration damping performance that is higher than the sky-hook control of the previous LS400. | ○ | — |
| Semi-Active Control (Sky-Hook Control) | Changes the damping force to a target value in accordance with the changes in the road surface or driving conditions. Thus, excellent ride comfort has been realized while ensuring a high level of vibration damping performance. | — | ○ |
| Imaginary Roll Damper Control | Changes the damping force to control the vehicle posture during cornering. As a result, excellent stability and controllability have been realized during cornering. | ○ | — |
| Anti-Roll Control | Changes damping force to harder. This control suppresses rolling and minimizes change of the vehicle posture, provided controllability. | — | ○ |
| Anti-Dive Control | Changes damping force to harder. This control suppresses nose diving of the vehicle during braking and minimizes changes of the vehicle posture. | ○ | ← |
| Anti-Squat Control | Changes damping force to harder. This control suppresses squatting of the vehicle during acceleration and minimizes change of the vehicle posture. | ○ | ← |
| Speed Sensitive Control | Changes damping force to harder. This control provides the excellent driving stability and controllability at high speeds. | ○ | ← |

► Vehicle Height Control ◀

| Control | Function | New LS430 | Previous LS400 |
|-----------------------|---|-----------|-------------------------------------|
| Auto-Leveling Control | Maintains vehicle height at a constant level regardless of the passenger and luggage weights. Operation of the height control switch changes the target vehicle height to “normal” or “high” level. | ○ | ← |
| High Speed Control | Controls vehicle height to a lower side than the height selected by the height control switch (to lower position if “normal” is selected or to “normal” if “high” is selected) when the vehicle is driven at a prescribed speed or higher. This provided aerodynamics and excellent stability at high speeds. | ○ | ← (“high” → “normal” only) |

2) Semi-Active Control (Non-Linear H^∞ Control)

In place of the sky-hook control of the previous LS400, non-linear H^∞ control has been adopted on the new LS430. This control smoothly changes the damping force to a target value in accordance with the changes in the road surface or driving conditions. Thus, excellent ride comfort has been realized while ensuring a high level of vibration damping performance.

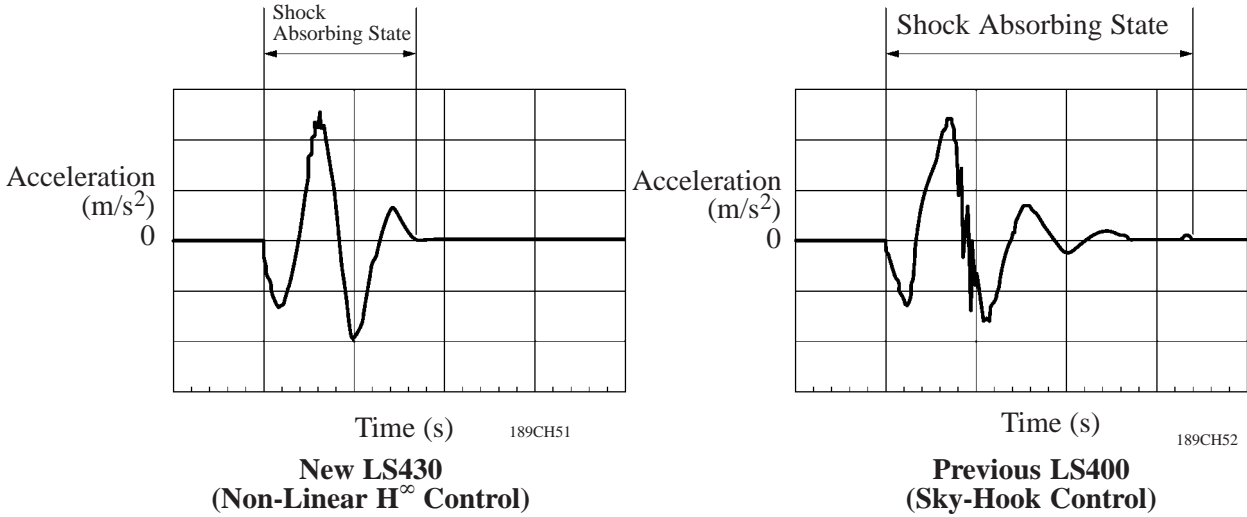

3) Imaginary Roll Damper Control

Changes the damping force to control the vehicle posture during cornering. As a result, excellent stability and controllability have been realized during cornering. This control assumes that two types of shock absorbers, (one for restraining roll and the other for restraining lift) are provided at an imaginary point on the inside of the turn of the vehicle. The function of these shock absorbers is to prevent the center of gravity of the vehicle from rising.

The damping force of the front and rear shock absorbers is controlled in order to control the vehicle's posture as in this imaginary condition.

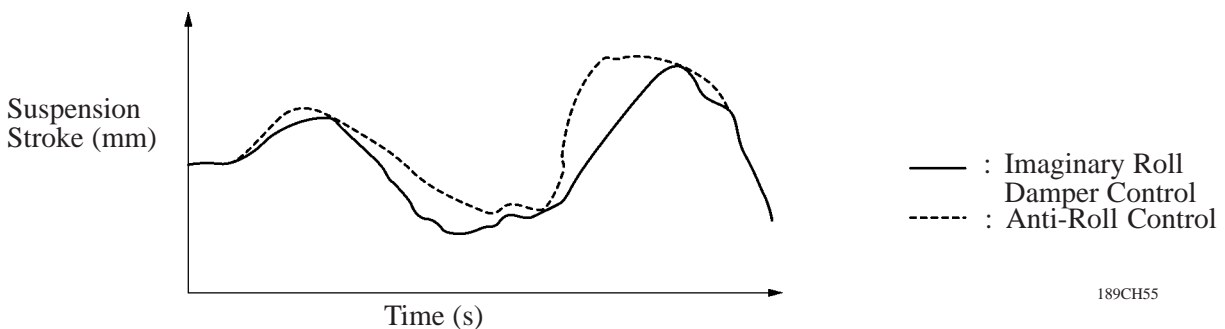
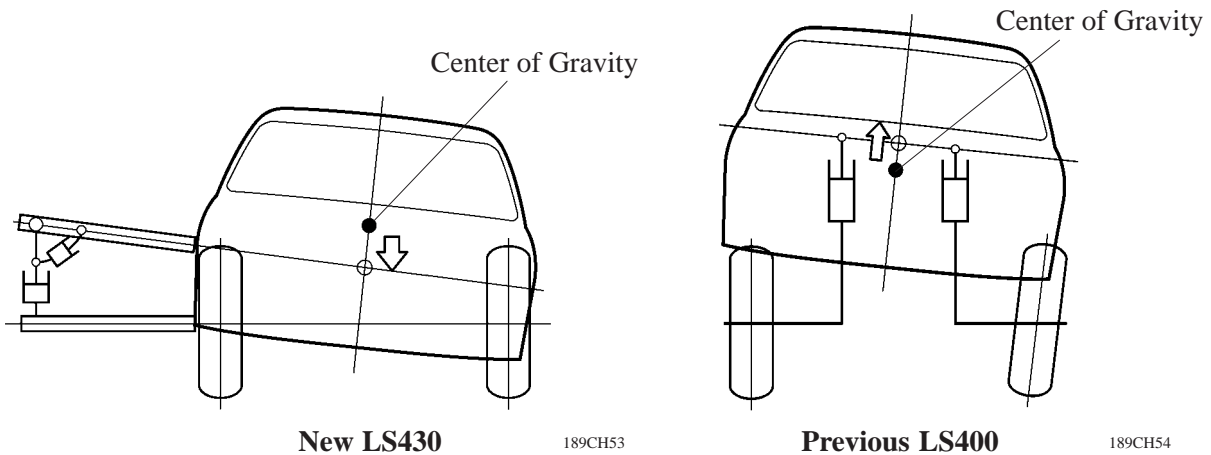

4) Self-Diagnosis

If the air suspension ECU detects a malfunction in this system, it blinks the LRC indicator light to alert the driver of the malfunction. The ECU will also store the codes of the malfunctions. The DTCs (Diagnostic Trouble Codes) can be accessed through the blinking of the LRC indicator light or the use of a LEXUS hand-held tester. For details, refer to the LEXUS LS430 Repair Manual (Pub. No. RM792E).

5) Fail-Safe

If a malfunction occurs in any of the sensors or actuator, the ECU prohibits the vehicle height control and/or the damping force control.

6) Active Test

The operation of the vehicle height control can be checked by shorting the terminal of the height control connector or using a hand-held tester, which directly activates the suspension control actuators. For details, refer to the LEXUS LS430 Repair Manual (Pub. No. RM792E).

■ AXLE

- A double-row angular ball bearing is used for both the front and rear axles.
- Part of the inner race is integrated with the shaft, thus optimizes the rigidity.

