

## ■ AUTOMATIC TRANSMISSION CONTROL SYSTEM

### 1. General

The automatic transmission control system of the new LS430's A650E automatic transmission and previous LS400's A650E automatic transmission are compared below.

System	Function	New LS430	Previous LS400
Shift Timing Control	The optimum shift pattern is selected from 2 shift patterns in the engine & ECT ECU by the pattern select switch. The engine & ECT ECU sends current to the solenoid valve No. 1, No. 2, No. 3 and/or No. 4 based on signals from each sensor and shifts the gear.	○	○
	<ul style="list-style-type: none"> <li>The vehicle speed at which downshifting into 1st gear during engine braking occurs has been increased to improve driveability.</li> <li>The hydraulic pressure passages, and solenoid valve construction have been optimized to achieve smooth shifting during the warm-up process following a cold startoff.</li> </ul>	○	—
Lock-up Timing Control	The optimum lock-up pattern is selected from 2 lock-up patterns in the engine & ECT ECU by the pattern select switch. The engine & ECT ECU sends current to the solenoid valve SLU based on signals from each sensor and engages or disengages the lock-up clutch.	○	○
Flex Lock-up Clutch Control	Controls the solenoid valve SLU, provides an intermediate mode between the ON/OFF operation of the lock-up clutch, and increase the operating range of the lock-up clutch to improve fuel economy.	○	○
	The operating range of the flex lock-up clutch has been expanded from the previous 5th and 4th gears to the 5th, 4th, and 3rd gears to improve fuel economy.	○	—
Line Pressure Optimal Control	Based on the throttle opening angle and various signals, the engine & ECT ECU sends a signal to solenoid valve SLT to generate line pressure according to the engine output and to effect a smooth gear shift change.	○	○
Clutch Pressure Control	To achieve smooth shifting, the solenoid valve SLN controls the accumulator back pressure in order to finely regulate the hydraulic pressure that is applied to the clutch.	○	○
	Uses the solenoid valve SLU to directly control the hydraulic pressure that is applied to the clutch.	○	○
Engine Torque Control	Retards the engine ignition timing temporarily to improve shift feeling during up or down shifting.	○	○
High Response Shift Control	Through the cooperative control with the ETCS-i (Electronic Throttle Control System-intelligent), and the electronic control of supply and discharge speed of the clutch and brake hydraulic pressure, excellent response has been realized.	○	○
AI (Artificial Intelligence)-SHIFT	Based on the signals from various sensors, the engine & ECT ECU determines the road conditions and the intention of the driver. Thus, the shift pattern is automatically regulated to an optimal level, thus improving driveability.	○	○
	The up shift prohibition region while driving uphill has been expanded to the 4th and 5th gears. The automatic downshift during downhill driving has been expanded to the 3rd and 4th gears to improve driveability.	○	—
Garage Shift Control	To restrain the vertical movement of the vehicle when the shift lever is moved from the D position to N, the clutch release speed has been optimized.	○	—
Shift Down Control	In order to ensure a smooth shift feel during downshifting to accelerate the vehicle, the hydraulic passages and control have been optimized.	○	—

## 2. Flex Lock-up Clutch Control

In addition to the conventional lock-up clutch control, a new flex lock-up clutch control has been adopted. In the low- to mid-speed range, this flex lock-up clutch control regulates the solenoid valve SLU to provide an intermediate mode between the ON/OFF operation of the lock-up clutch in order to improve the energy-transmitting efficiency in this range.

As a result, the operating range of the lock-up clutch has been increased and fuel economy has been improved. The flex lock-up clutch control operates in the 3rd, 4th and 5th gears in the D range.

The lock-up timing control operates in the 5th gear in the D range and in the 4th gear in the 4 range.

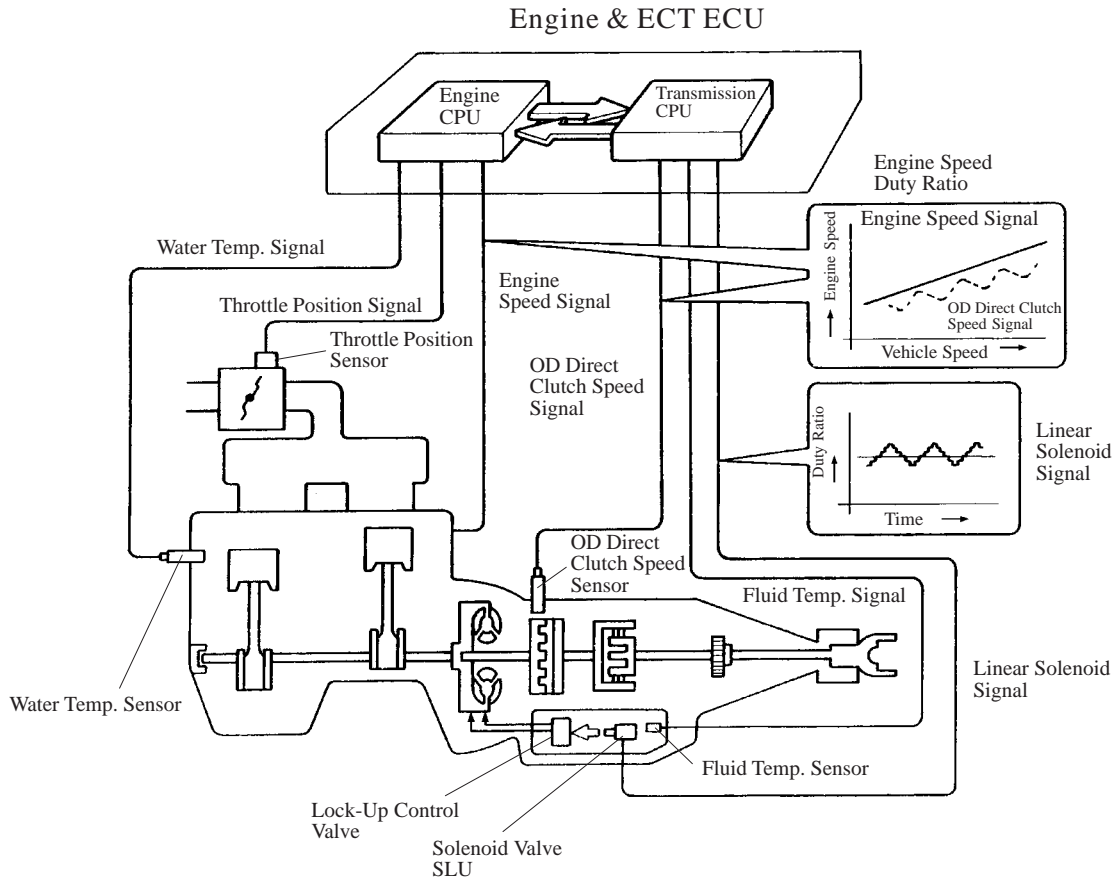

189CH11

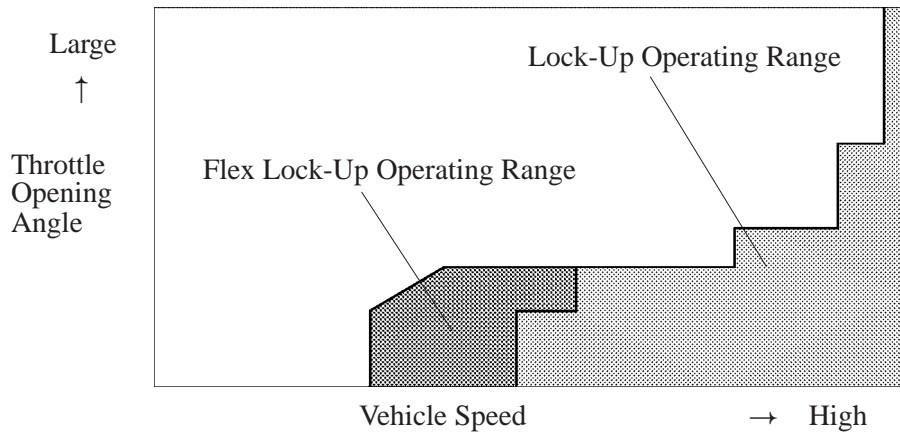

151CH26

### 3. Line Pressure Optimal Control

The line pressure controlled by using a solenoid valve SLT.

Controls the line pressure to an optimal value based on real-time engine torque information provided by the engine.

This enables the line pressure to be finely controlled at a high rate of precision in accordance with the engine output and conditions, thus realizing smooth shift characteristics.

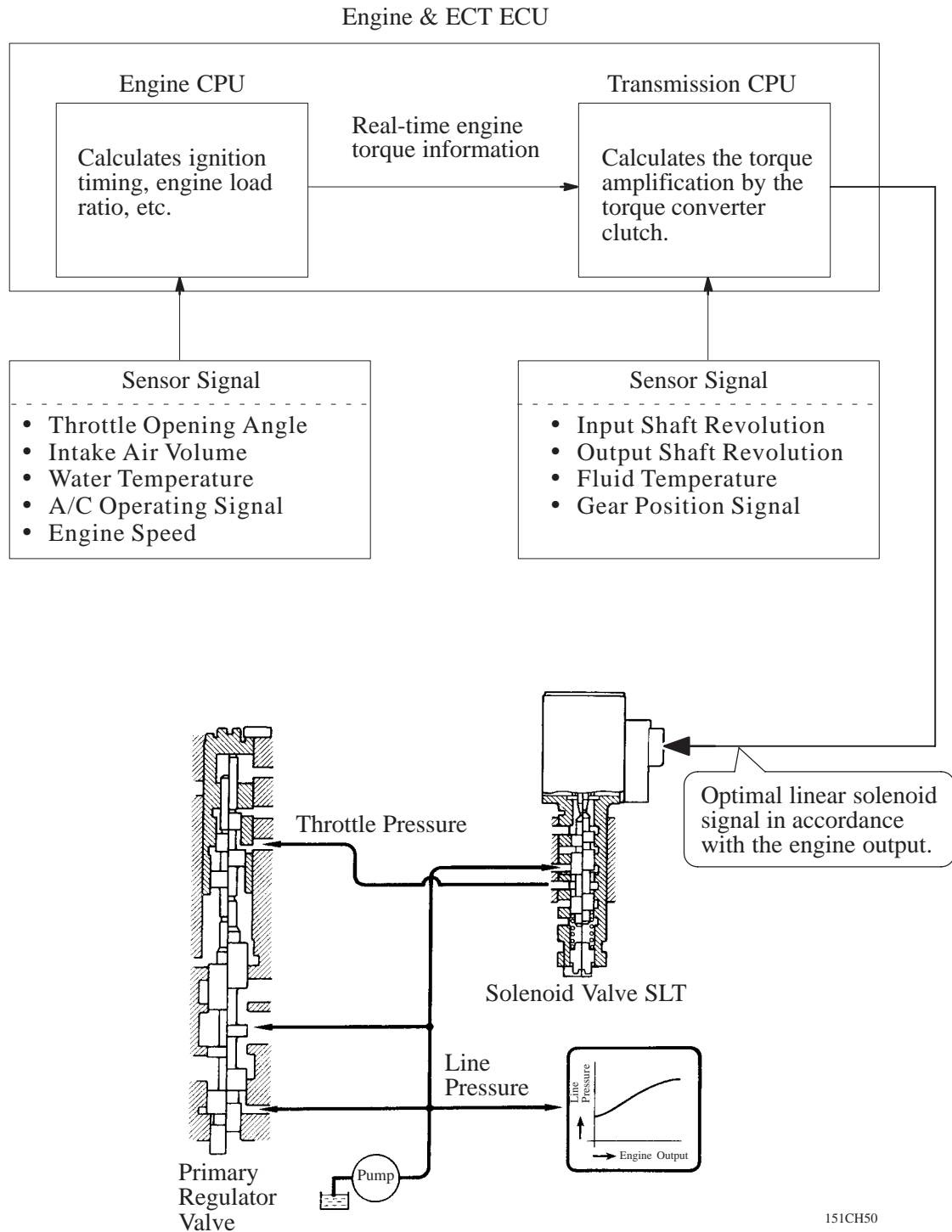

CH

## 4. Clutch Pressure Control

### General

Due to the development of the direct clutch pressure control and the clutch-to-clutch shift control, a 5-speed configuration has been achieved without increasing the accumulator and the one-way clutch.

As a result, a compact and lightweight automatic transmission has been realized.

### Direct Clutch Pressure Control System

A direct clutch pressure control system has been adopted for shifting from the 1st to 2nd gear. In contrast to the clutch pressure control system of a conventional automatic transmission that uses an accumulator to execute clutch pressure control, this system controls the solenoid valve SLU to regulate the 2nd brake (B3) hydraulic pressure for the 2nd gear, via the B3 control valve, without using an accumulator.

This realizes highly precise hydraulic control that cannot be achieved with a clutch pressure control system that uses an accumulator.

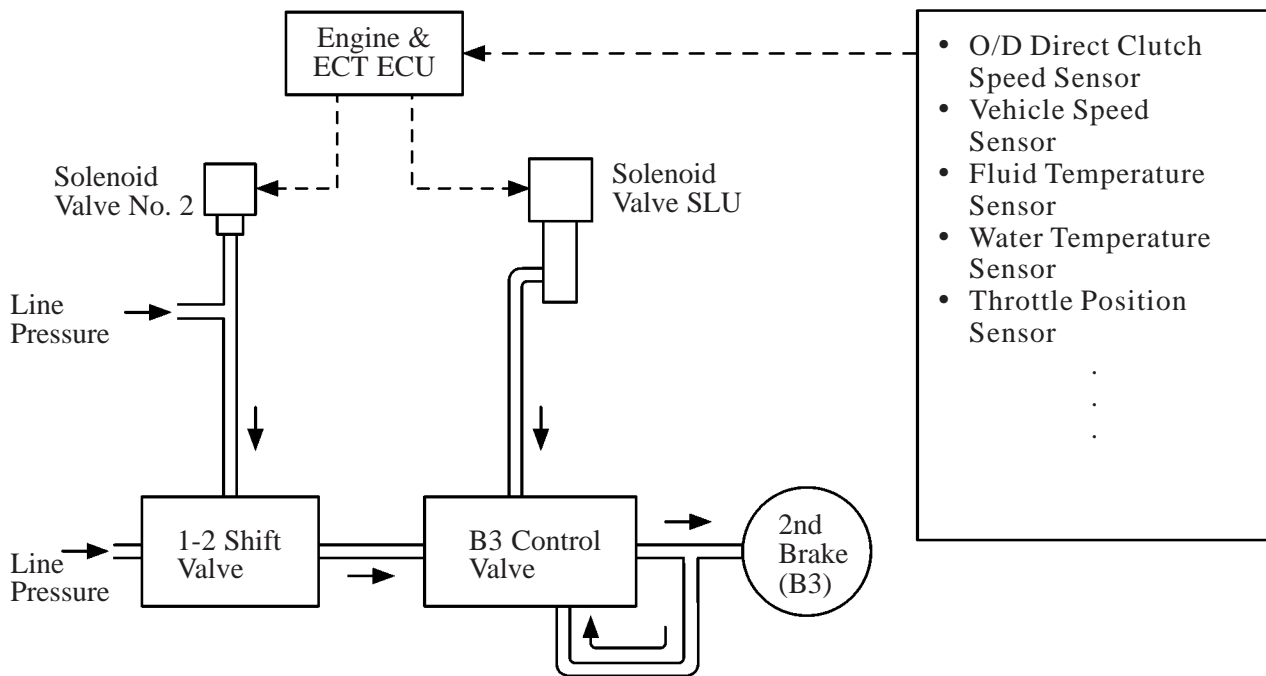

## Clutch to Clutch Shift Control

To ensure the reliability of clutch-to-clutch control, the 2nd brake (B3) hydraulic pressure for the 2nd gear is regulated in link with the 3rd brake (B2) hydraulic pressure for the 3rd gear.

Also, optimal shift characteristics have been achieved through optimal hydraulic pressure settings and switchover timing in which the clutch rpm and input torque estimate values have been utilized.

### a. Outline of Hydraulic Circuit

- This control is accomplished by applying the 3rd brake (B2) hydraulic pressure to the B3 control valve and relating the 2nd brake (B3) hydraulic pressure to the 3rd brake hydraulic pressure.
- The 2nd brake (B3) hydraulic pressure is controlled by the solenoid valve SLU.
- The solenoid valve No. 3 controls the B-2 release control valve and controls the discharge speed of the 3rd brake (B2) hydraulic pressure.

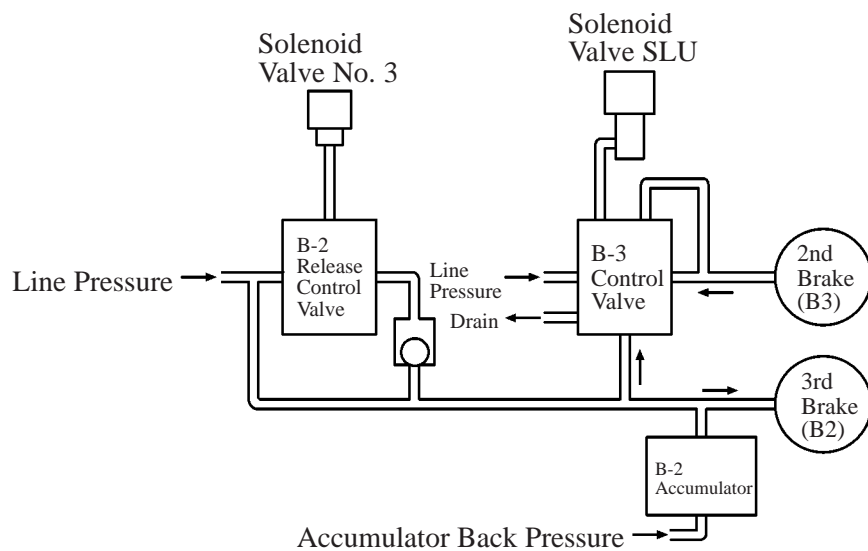

2nd Gear to 3rd Gear

151CH43

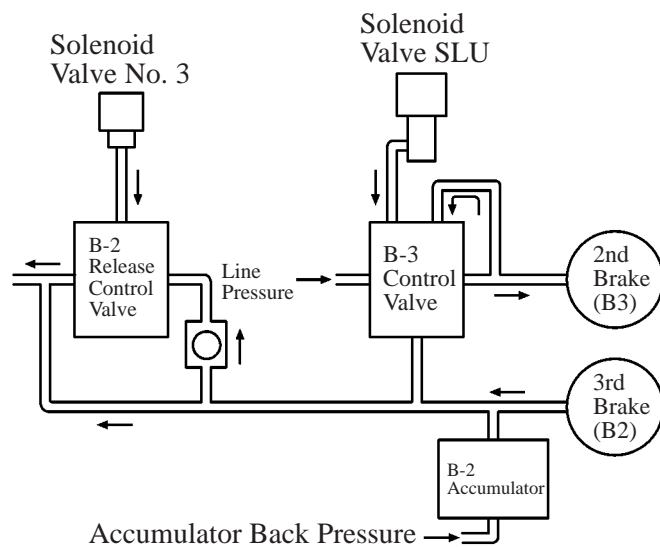

3rd Gear to 2nd Gear

151CH44

## b. Outline of Control Methods

The clutches are controlled by optimal shift timing and hydraulic pressure in accordance with clutch rpm and engine torque information.

### i) Up Shift

The 2nd brake hydraulic pressure is regulated by the hydraulic pressure from the solenoid valve SLU and from the 3rd brake hydraulic pressure in accordance with input torque. Based on the input shaft speed during shifting, the solenoid valve SLU is corrected to control the 2nd brake.

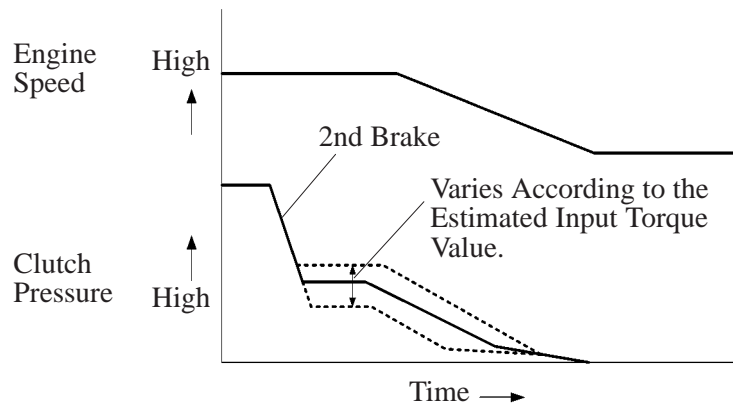

151CH45

### ii) Down Shift

Based on changes in engine speed, the timing for synchronizing the clutch is forecasted and the 2nd brake hydraulic pressure is increased suddenly.

Based on the vehicle speed, the discharge speed of the 3rd brake hydraulic pressure is switched by the solenoid valve SLU to achieve both reduced shift shock and improved shift response.

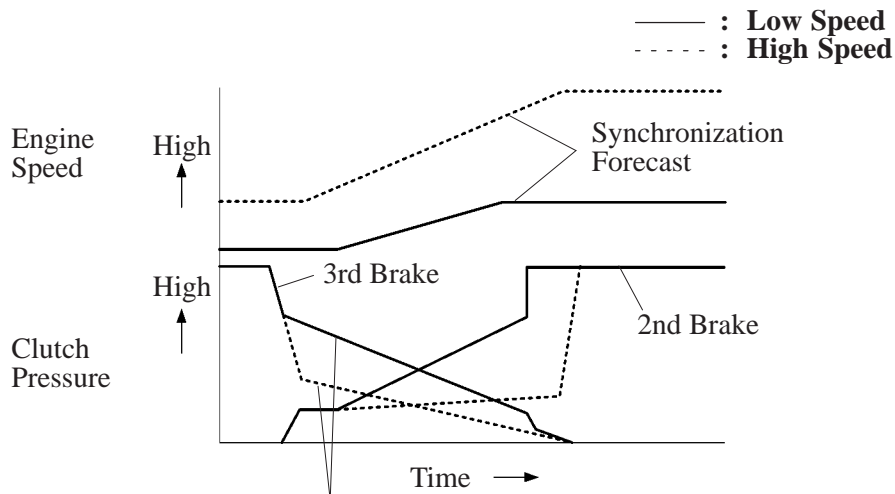

Based on the vehicle speed, the discharge speed of the 3rd brake hydraulic pressure is switched.

151CH46

## 5. High Response Shift Control

### General

A high-response clutch hydraulic pressure control, which executes high-response engine torque-up control during shifting and optimizes the supply and discharge speed of the clutch hydraulic pressure through electronic control, has been adopted. As a result, both the reduction of shift shock and the improvement of shift response have been realized at high levels.

### High Response Engine Torque Up Control

Performs cooperative control that retards the engine ignition timing at the same when time the throttle valve is opened when the shift lever is downshifted manually. This realizes high-response engine torque control. As a result, a considerable reduction in shift time has been achieved.

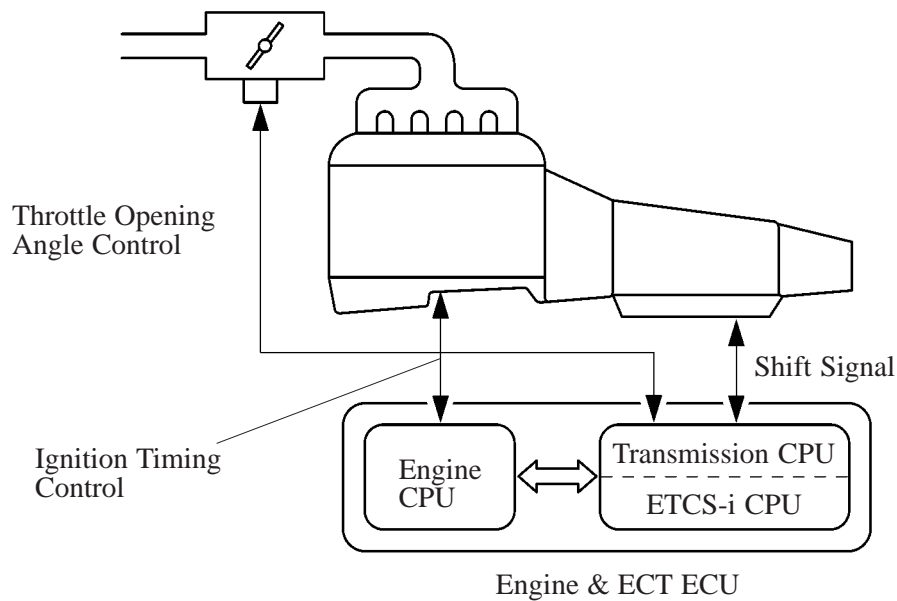

151CH27

### High Response Clutch Hydraulic Pressure

A conventional automatic transmission ordinarily had one circuit each for supplying and discharging the hydraulic pressure to the clutch and brake.

However, in the A650E automatic transmission, a mechanism has been added to control the solenoid valves No. 3 and No. 4 to activate the control valve, which switches the supply and discharge speeds of the clutch and brake pressure.

As a result, the hydraulic pressure can be supplied or discharged slowly, when the reduction of shift shock is more important, or supplied quickly, when response is more important. Thus, a shift feeling that is constantly favorable has been realized.

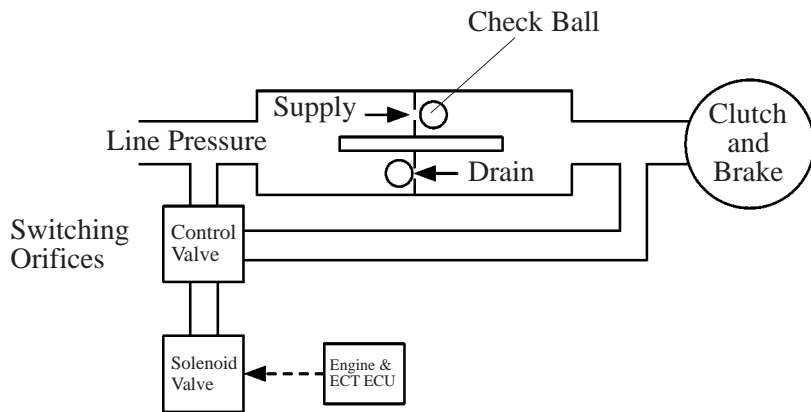

**A650E Automatic Transmission**

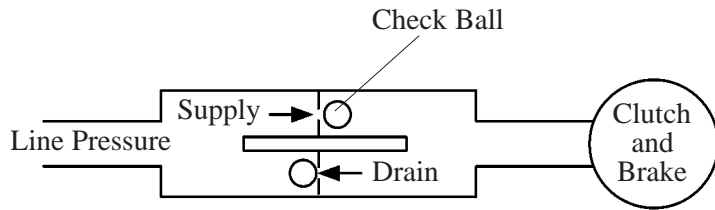

**Conventional Automatic Transmission**



## 6. AI (Artificial Intelligence)-SHIFT Control

### General

In addition to the switching of the shift pattern through the pattern select switch, the AI-SHIFT control enables the engine & ECT ECU to estimate the road conditions and the driver's intention in order to automatically switch the optimal shift pattern. As a result, comfortable ride has been realized at high levels.

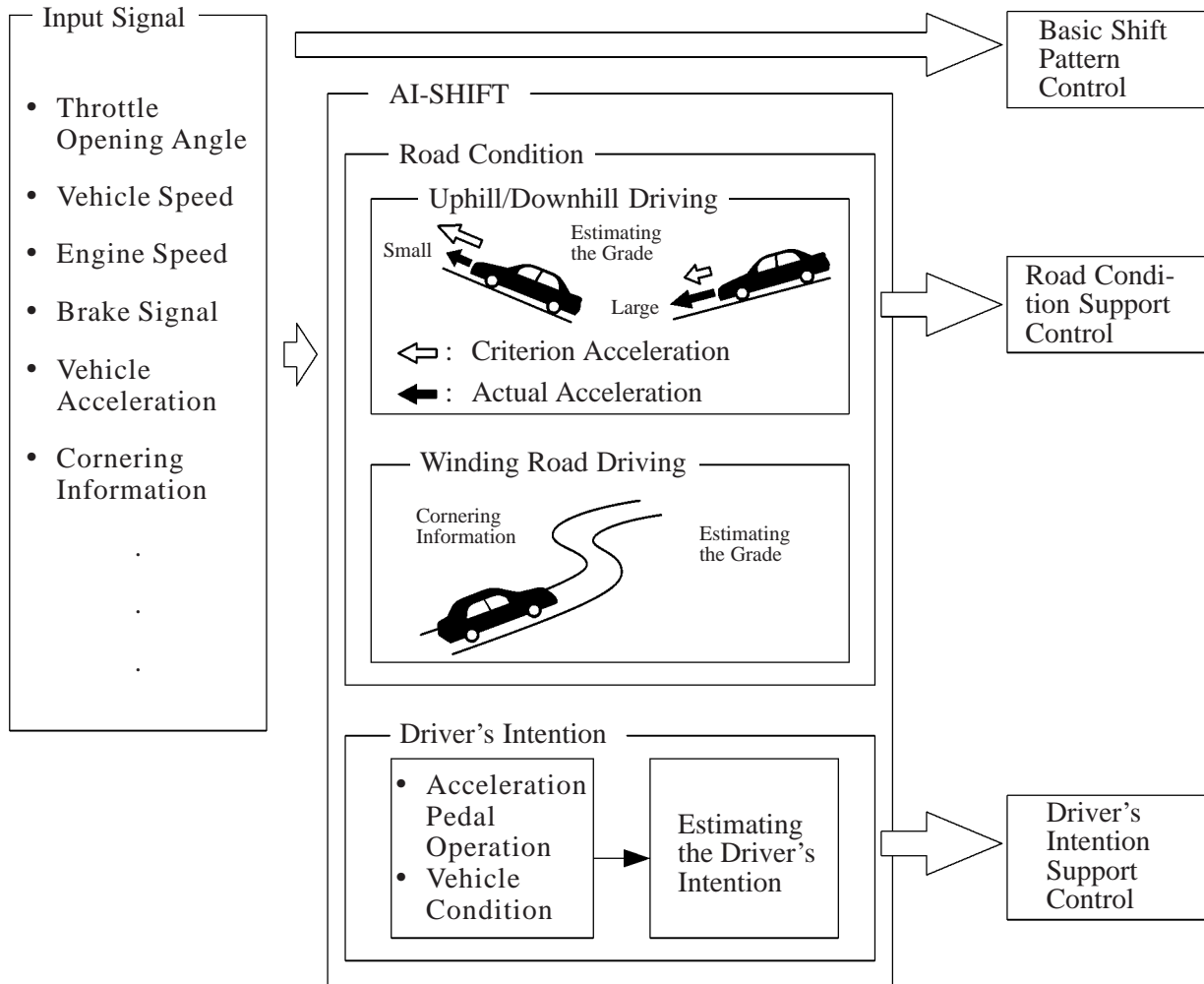

CH

## Road Condition Support Control

In the conventional automatic transmission, if the vehicle is accelerated or decelerated while driving uphill, depending on the circumstances, the transmission shifted up or down frequently.

While driving downhill, because the transmission is upshifted when the throttle valve is almost completely closed, the transmission upshifted quickly even at low driving speeds, occasionally creating a condition in which it was difficult to apply the engine brake.

Therefore, in the road condition support control, the uphill or downhill driving conditions are assessed through the throttle opening angle, vehicle speed, etc. to achieve an optimal and constant driving force by restraining the transmission from upshifting to the 4th or 5th gear while driving uphill.

The transmission automatically downshifts to the 3rd or 4th gear so that an optimal engine brake can be achieved while driving downhill.

To prevent unnecessary shifting, this system assesses a winding road condition in accordance with the cornering conditions, in order to achieve optimal shift control at all times.

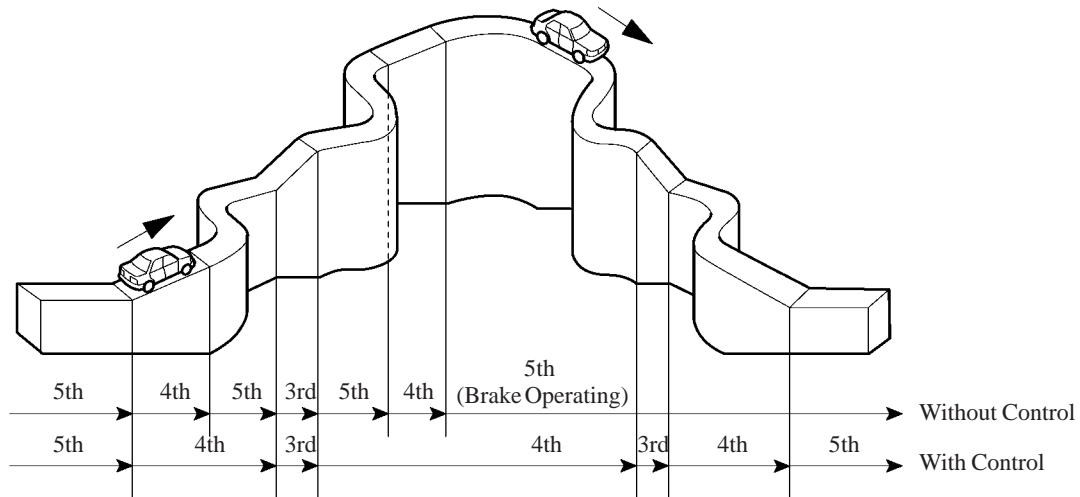

189CH13

## Driver's Intention Support Control

Estimates the driver's intention based on the accelerator operation and vehicle condition to switch to a shift pattern that is well-suited to each driver, without the need to operate the shift pattern select switch.