

ENHANCEMENT OF PRODUCT APPEAL

■ ADDRESSING MINOR COLLISION DAMAGE

A large number of structures that minimize damage to the vehicle as much as possible during minor collisions* have been adopted, and measures listed below that keep the cost of the repair or replacement parts have been taken.

*: Collision with off-set rate 40 % and vehicle speed by 15 km/h

1. Front

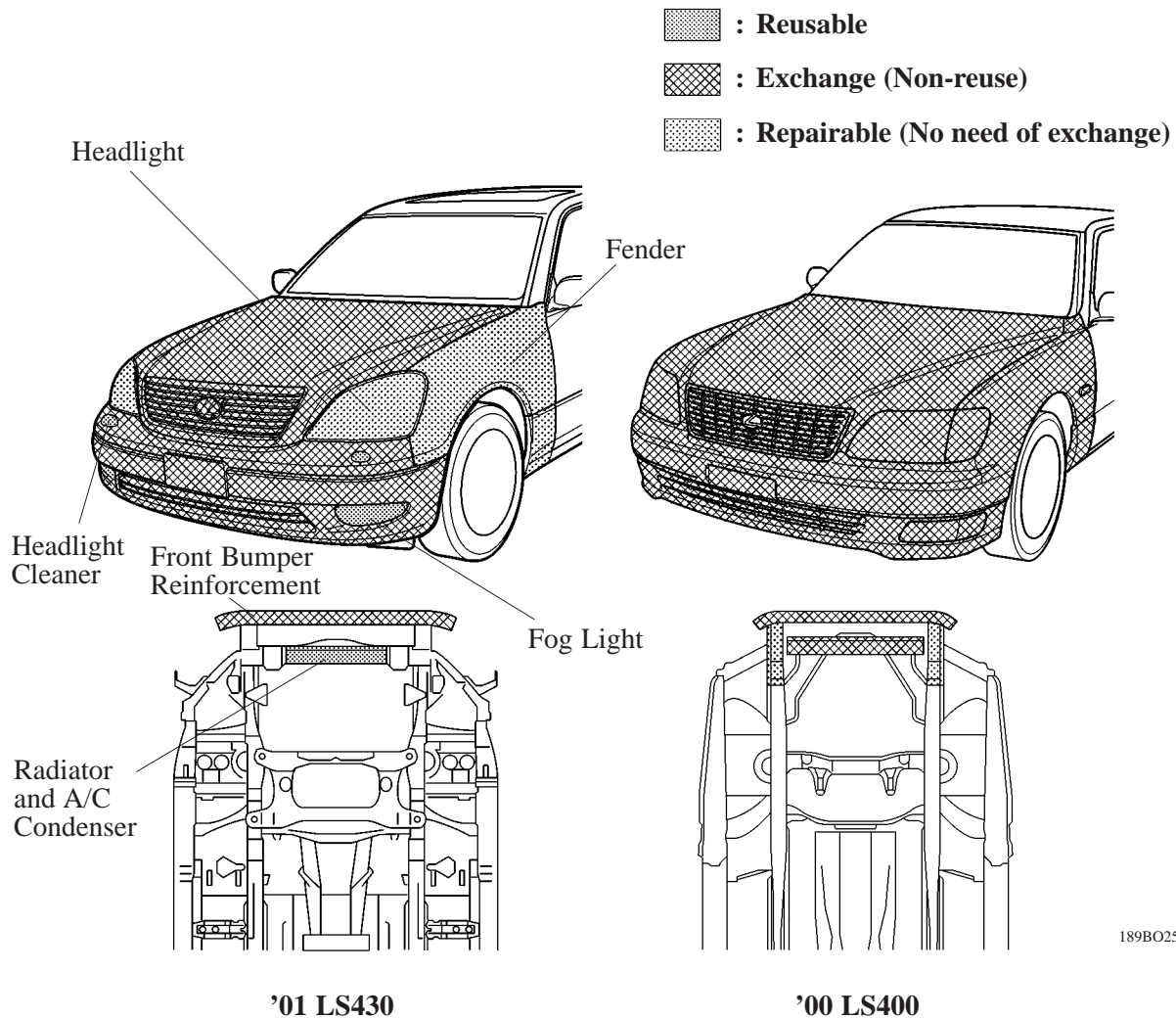

- The retaining stays for the headlights have been provided separately from the housing to make it less susceptible to damage during a collision.
- The construction and the strength of the front side member has been optimized to restrain the amount of deformation during a collision as much as possible.
- The number of brackets that secure the front bumper in place has been minimized to reduce the number of replacement parts.
- A large number of bolt-on structures have been adopted for various parts in the front area so that the repair time can be shortened.
- The A/C condenser, radiator, air cleaner, front height control valve, pipes, and wiring harnesses have been optimally located to minimize damage to the expensive parts during a collision as much as possible.



BO

2. Rear

- To achieve a construction that can efficiently absorb the impact energy during a collision, the following measures have been taken: the strength of the rear floor side member has been optimized, the construction of the rear bumper has been optimized, and the rear bumper reinforcements and rear bumper arms made of aluminum have been adopted.
- The number of brackets that secure the rear bumper in place has been reduced in order to reduce the number of replacement parts as much as possible.

-  : Reusable
-  : Exchange (Non-reuse)
-  : Repairable (No need of exchange)

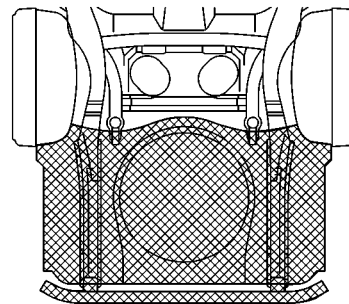
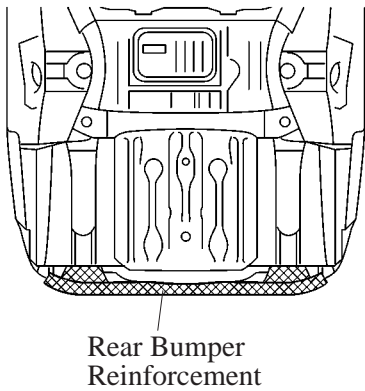
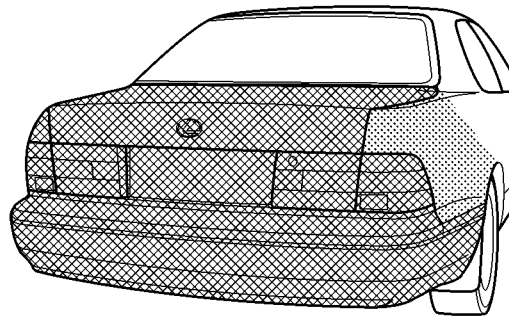
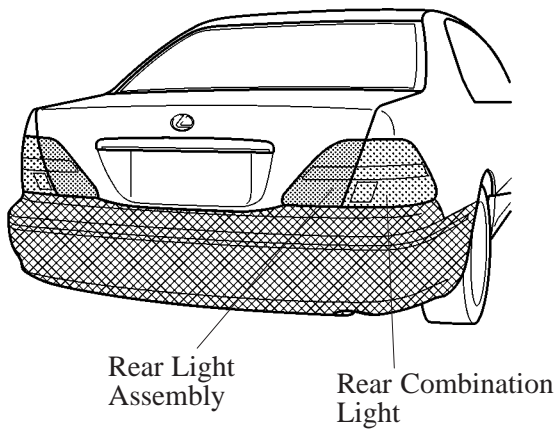

189B026

'01 LS430

'00 LS400