

■ SRS AIRBAG SYSTEM

1. General

- In conjunction with impact absorbing structure for front collision, the SRS (Supplemental Restraint System) driver and front passenger airbags have been designed to help reducing the shocks to the heads and chests of the driver and front passenger in the event of a front collision as supplements to the seat belts.

This system is a 3-sensor type airbag system to detect the impact during a front collision using the airbag sensor assembly and two front airbag sensor assemblies, and to make the airbag system and seat belt pretensioner operate as well.

- In order to detect the extent of the collision during the initial stages of the collision in further detail, the previous mechanical type deceleration sensors have been changed to electrical type deceleration sensors. On the new LS430, these sensors are located in the two front airbag sensor assemblies in the engine compartment.

Accordingly, the deployment output of the airbag for the front passenger can be controlled in two stages in accordance with the extent of the collision. To support this control, a new front passenger airbag assembly has been adopted.

- In conjunction with impact absorbing structure for side collision, the SRS side and curtain shield airbags have been designed to help reducing the impact energy that is transmitted to the driver, front passenger, and rear outer passenger in the event of a side collision.
- On the new LS430, a curtain shield airbag system that helps reduce the impact applied to the front and rear seat occupants with a single curtain shield airbag has been adopted.

In conjunction with this system, a side and curtain shield airbag sensor assembly has been provided at the bottom of the center pillar and a curtain shield airbag sensor assembly at the bottom of the rear pillar.

- In this system, a front side collision is detected by the side and curtain shield sensor assembly in order to simultaneously deploy the side and curtain shield airbags. A rear side collision is detected by the curtain shield airbag sensor assembly and the airbag sensor assembly in order to deploy only the curtain shield airbag.
- A function that detects whether or not the front passenger seat is occupied with the occupant detection sensor and seat belt buckle switch and prohibits the operation of the front passenger airbags (front and side) and front passenger seat belt pretensioner has been adopted in the SRS airbag system.
- The Airbag sensor assembly transmits the airbag deployment signal to the ECUs (Theft Deterrent ECU and Engine ECU) via the BEAN (Body Electronics Area Network) in order to effect the respective controls (collision door lock release control, fuel pump control, and Lexus link system).

2. System Diagram

► Front Airbag Operation ◀

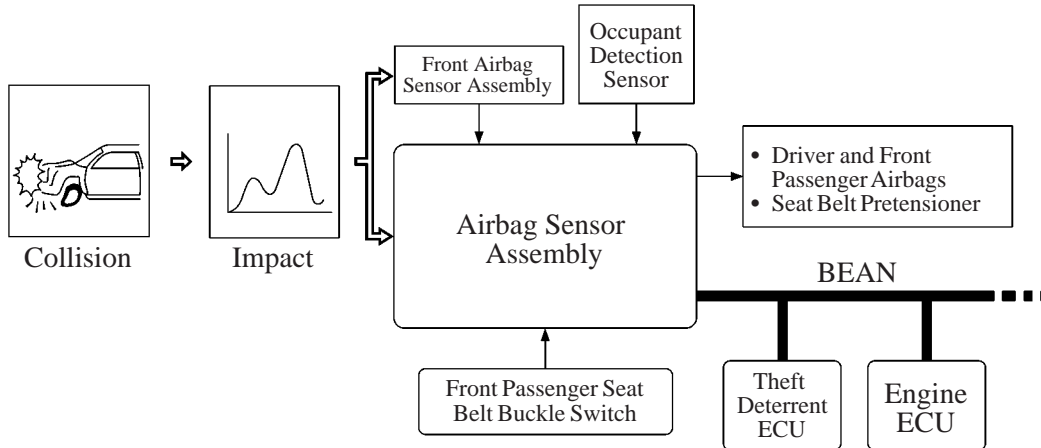

189BE120

► Side and Curtain Shield Airbag Operation ◀

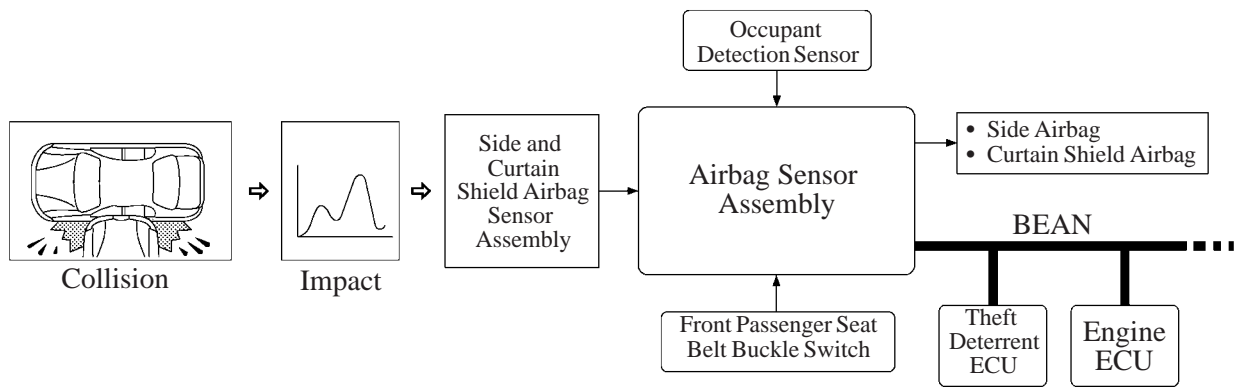

189BE121

► Curtain Shield Airbag Operation ◀

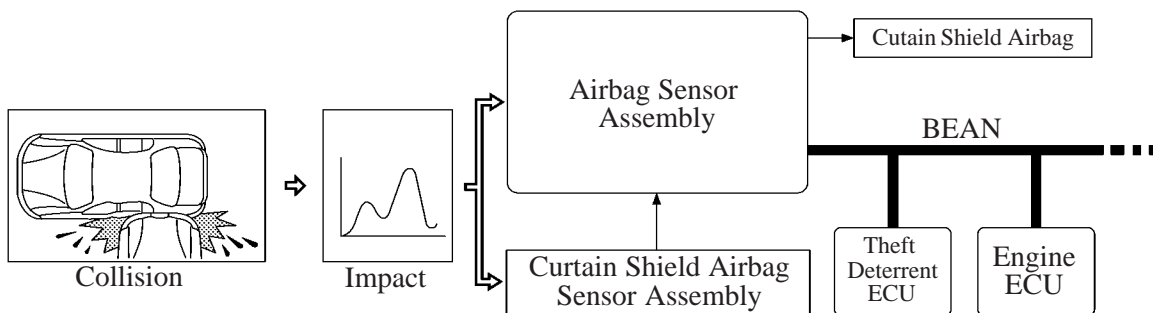

189BE122

3. Layout of Component

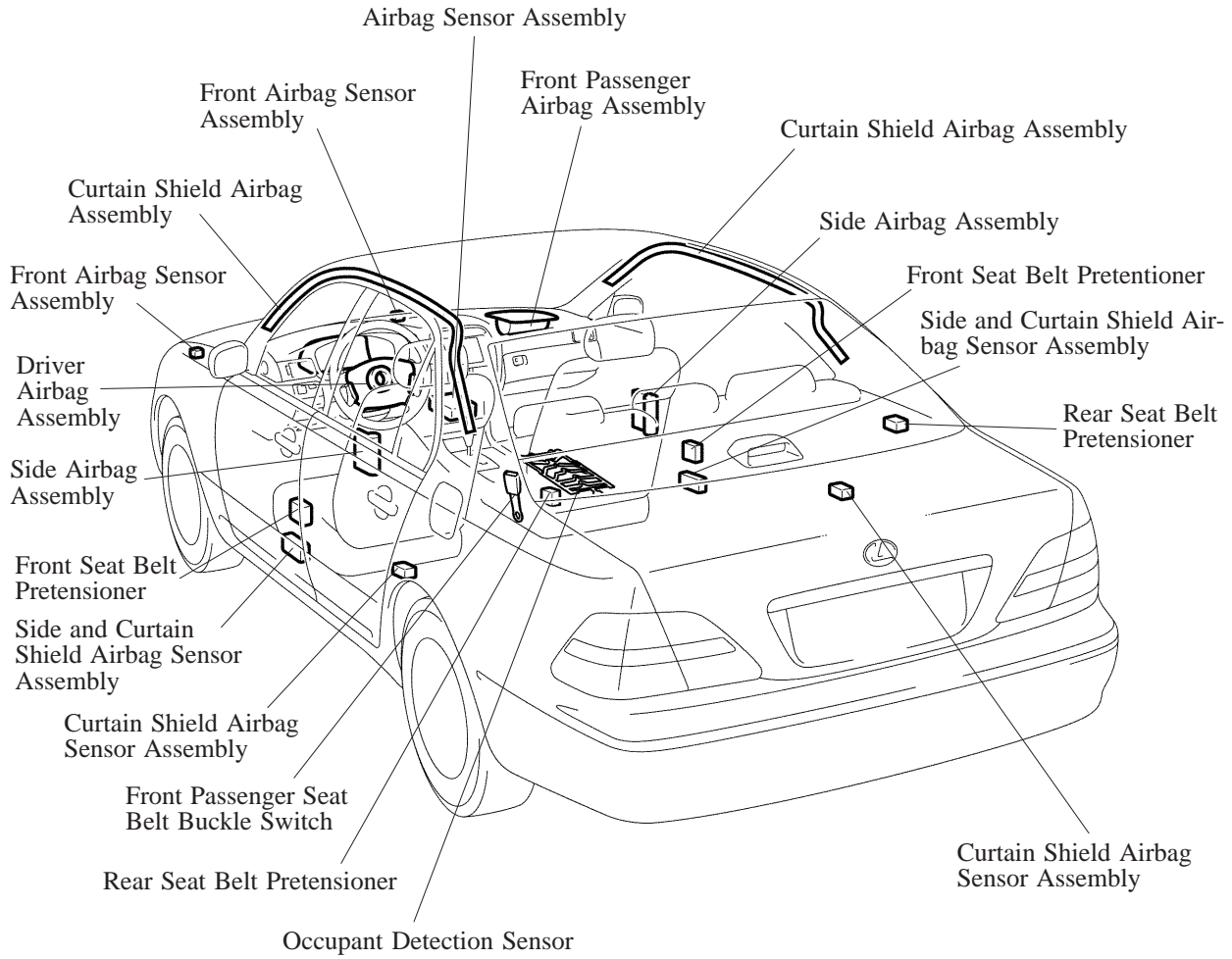

4. Wiring Diagram

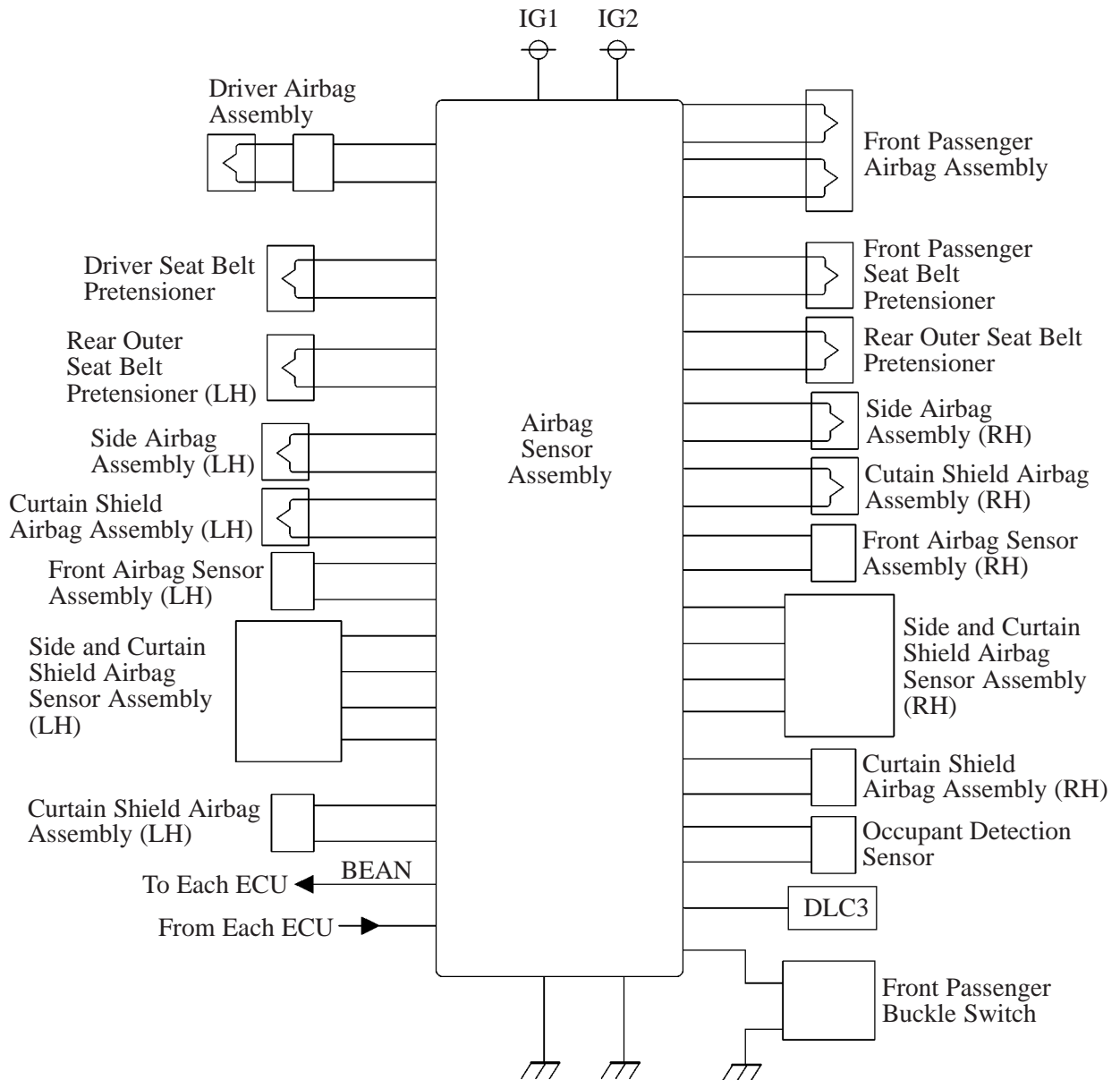

BE

5. Construction and Operation

Front Airbag Sensor Assembly

- The front airbag sensor assembly is mounted on the right and left front side members.
- On the new LS430, the previous mechanical type front airbag sensor assembly (consisting of movable and stationary contact points) has been changed to an electrical (deceleration sensor) type front airbag sensor assembly.
- The deceleration sensor is enclosed in the front airbag sensor assembly based on the deceleration of the vehicle that occurs during a front collision. The distortion that is created in the sensor is converted into an electric signal. Accordingly, the extent of the initial collision can be detected in detail.

Side and Curtain Shield Airbag Sensor Assembly

- The side and curtain shield airbag sensor assembly is mounted on the right and left center pillars. It receives signals from the deceleration sensor enclosed in the side and curtain shield airbag sensor assembly, judges whether the side and curtain shield airbags must be activated or not, and diagnoses system malfunctions.
- The side and curtain shield airbag sensor assembly consists of deceleration sensor, safing sensor, ignition control circuit, diagnosis circuit. The basic construction and operation are the same as in the current side airbag sensor assembly.

Curtain Shield Airbag Sensor Assembly

- The curtain shield airbag sensor assembly is mounted on the right and left rear pillars. This sensor assembly uses a deceleration sensor for detecting the deceleration speed during a rear side collision.
- The deceleration sensor is enclosed in the curtain shield airbag sensor assembly based on the deceleration of the vehicle that occurs during a rear side collision. The distortion that is created in the sensor is converted into an electric signal.

Occupant Detection Sensor

The occupant detection sensor, which is enclosed in the seat cushion of the front passenger seat, is used to detect whether or not the front passenger seat is occupied.

This sensor, which is shaped as illustrated below, consists of a construction in which two sheets of electrodes sandwich a spacer. When the occupant is seated, the electrode sheets come in contact with each other through the hole that is provided in the spacer portion, thus enabling the current to flow. As a result, the Airbag sensor assembly detects the presence of the occupant. This sensor is basically the same as the occupant detection sensor of the conventional seat belt warning system, except that it is shaped differently.

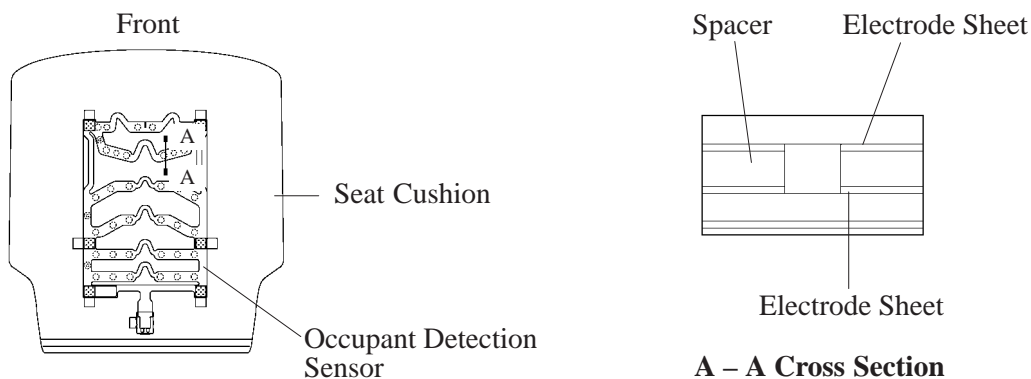

Airbag Sensor Assembly

1) General

- The Airbag sensor assembly is mounted on the center floor under the instrument panel.
- The Airbag sensor assembly consists of deceleration sensor, safing sensor, electronic safing sensor, ignition control circuit, diagnosis circuit.
- The Airbag sensor assembly receives signals from the deceleration sensor and safing sensor enclosed in the Airbag sensor assembly and front airbag sensor assembly, and judges whether the driver and front passenger airbags and seat belt pretensioner must be activated or not, and then diagnosis system malfunctions.
- Upon receiving instruction signals from the side and curtain shield airbag sensor assembly, the airbag sensor assembly causes the side and curtain shield airbags to deploy.
- The Airbag sensor assembly receives signals from the deceleration sensor and electronic safing sensor enclosed in the Airbag sensor assembly and curtain shield airbag sensor assembly, and judges whether the curtain shield airbag must be activated or not, and then diagnosis system malfunctions.
- The Airbag sensor assembly transmits the airbag deployment signal to the ECUs (Theft Deterrent ECU and Engine ECU) via the BEAN (Body Electronics Area Network) in order to effect the respective controls (collision door lock release control, fuel pump control, and Lexus link system).

2) Deceleration Sensor, Ignition Control Circuit

- The deceleration sensor is enclosed in the airbag sensor assembly. Based on the deceleration of the vehicle that occurs during a front or rear side collision, the distortion that is created in the sensor is converted into an electric signal. This signal is a linear representation of the deceleration rate.
- The ignition control circuit performs a prescribed calculation based on the signal output by the deceleration sensors of the Airbag sensor assembly and front airbag sensor assemblies. If these calculated values are larger than a predetermined value, it activates the ignition operation.

3) Safing Sensor

The safing sensor is enclosed in the Airbag sensor assembly. The sensor turns ON and outputs an ON signal to the Airbag sensor assembly if a deceleration force that is higher than a predetermined value is applied to the safing sensor as a result of a frontal collision.

4) Electronic Safing Sensor

The electronic safing sensor is enclosed in the Airbag sensor assembly. The sensor turns ON and outputs an ON signal to the Airbag sensor assembly if a deceleration force that is higher than a predetermined value is applied to the electronic safing sensor as a result of a rear side collision.

5) Back-Up Power Source

The back-up power source consists of a power supply capacitor and a DC-DC converter. In case of a power system failure during a collision, the power supply capacitor discharges and supplies electric power to the system. The DC-DC converter is a boosting transformer when the battery voltage drops below a certain level.

6) Diagnosis Circuit

This circuit constantly diagnoses the system for any malfunction. When a malfunction is detected, it lights up the SRS warning light on the combination meter to alert the driver.

7) Memory Circuit

When a malfunction is detected by the diagnosis circuit, it is coded and stored in this memory circuit.

Front Airbag Assembly

1) For Driver

The front airbag assembly is comprised of a initiator, enhancer, propellant grain. The basic construction and operation are the same as in the current front airbag assembly.

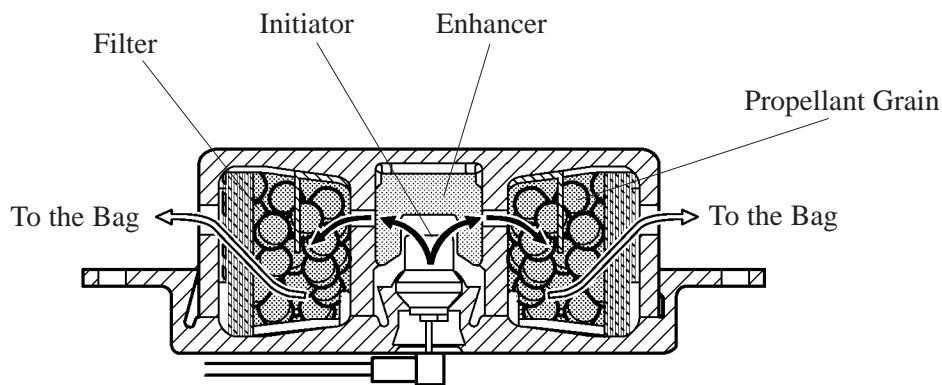

➔ : Propagation of Fire
⇨ : Flow of Nitrogen Gas

152BE46

CAUTION

The primer is ignited even by a feeble current. As it is dangerous, never measure the resistance of the primer with a volt/ohmmeter, etc.

2) For Front Passenger

To support the two-stage output control, the front passenger airbag assembly is divided into two portions, the initiator and the propellant. Other basic construction and operation are the same as in the current front passenger airbag assembly.

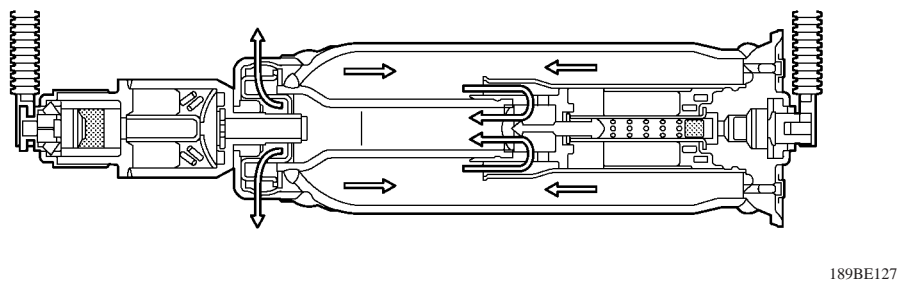
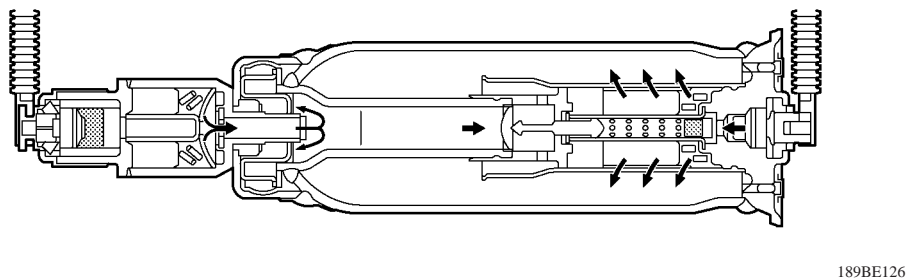
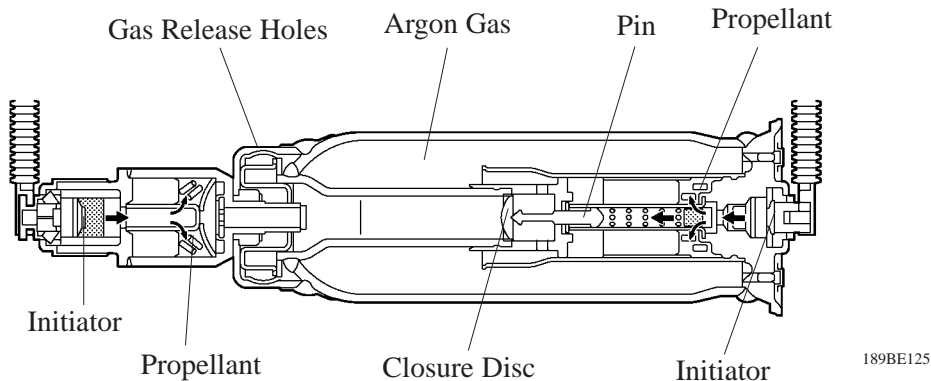

BE

CAUTION

The primer is ignited even by a feeble current. As it is dangerous, never measure the resistance of the primer with a volt/ohmmeter, etc.

Side Airbag Assembly

The side airbag assembly is integrated inside the case and located in the outer side of the seatback. The side airbag assembly is comprised of a squib, propellant grain, gas and pressure bulkhead. The basic construction and operation are the same as in the current side airbag assembly.

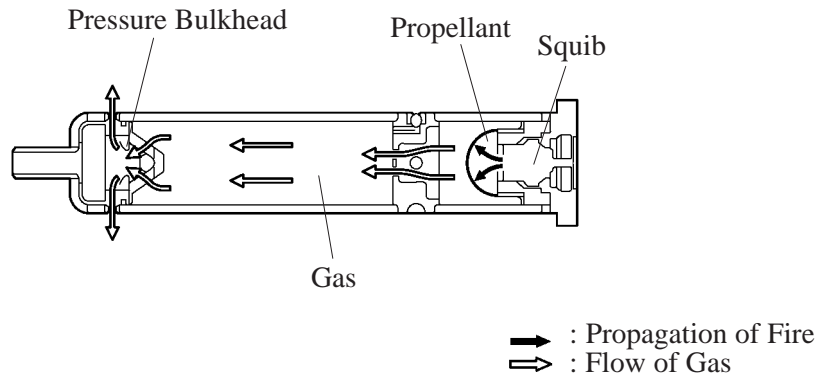

189BE128

CAUTION

The primer is ignited even by a feeble current. As it is dangerous, never measure the resistance of the primer with a volt/ohmmeter, etc.

Curtain Shield Airbag Assembly

The curtain shield airbag assembly is installed on the rear pillar. The curtain shield airbag assembly is comprised of an igniter, bracket, nail, break washer, container, and compressive bag.

► Inflator and Bag ◀

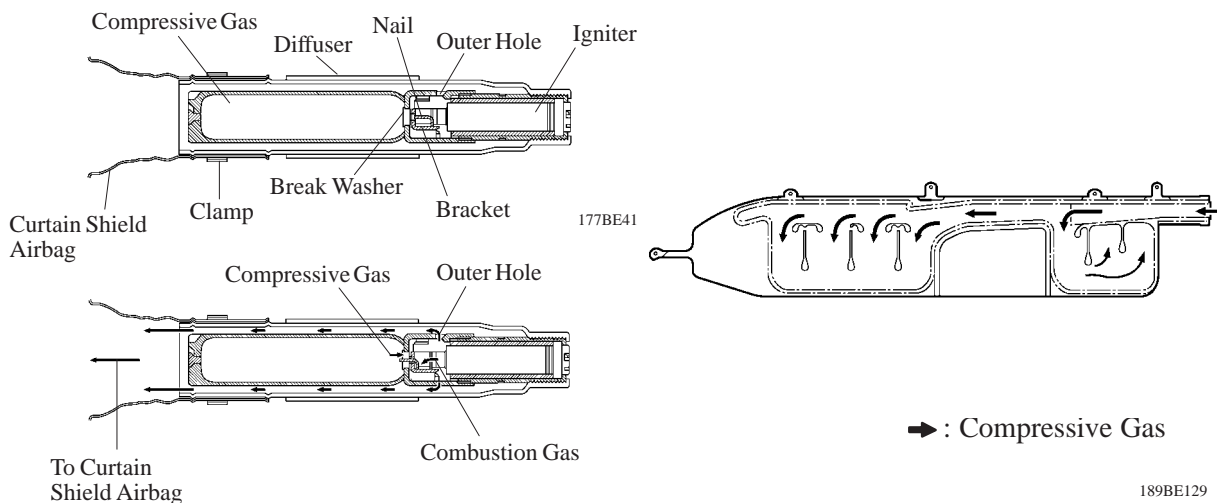

177BE41

177BE43

189BE129

CAUTION

The igniter is ignited even by a feeble current. As it is dangerous, never measure the resistance of the igniter with a volt/ohmmeter, etc.

SRS Warning Light

The SRS warning light is located on the combination meter.

It comes on to alert the driver about the system trouble when a malfunction is detected in self-diagnosis of the airbag sensor assembly and side airbag sensor assembly. In normal operating conditions when the ignition switch is turned ON position, the light comes on for about 6 seconds and then goes off.

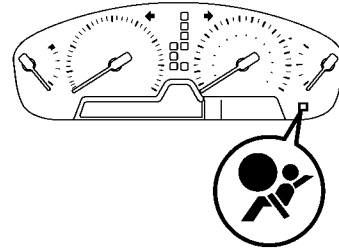

SRS Warning Light

189BE130

6. System Operation

Ignition Judgement and Conditions

1) Front Collision

- When the vehicle collides in the hatched area (Fig. 1) and shock is larger than a predetermined level, the airbags (driver and front passenger) are activated automatically. The deceleration sensor of the Airbag sensor assembly judge the need for ignition in response to collisions within the hatched area based on the signal from the deceleration sensor of the front airbag sensor assembly.
- Safing sensor of the Airbag sensor assembly is designed to be turned on by a smaller deceleration rate than the deceleration sensor. As illustrated in Fig. 2 below, ignition is caused when flows to the squib, when happens when the safing sensor and the deceleration sensor go on simultaneously.

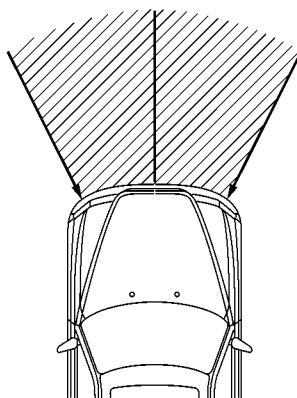

Fig. 1

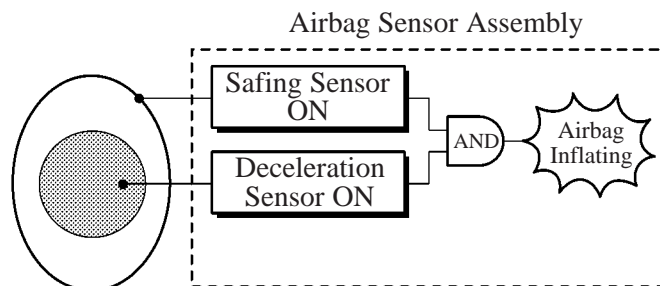
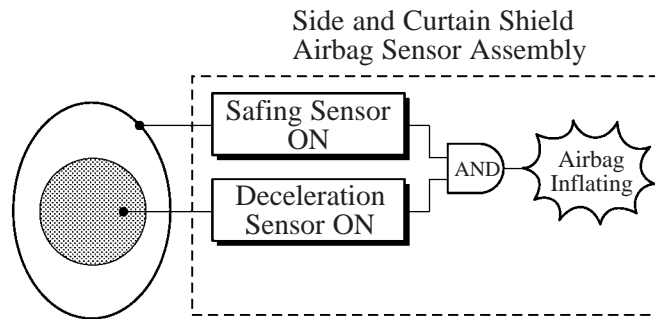

Fig. 2

189BE131

2) Front Side Collision

Safing sensor of the side airbag sensor assembly is designed to be activated by a smaller deceleration rate than the deceleration sensor of the side and curtain shield airbag sensor assembly. As illustrated below, ignition is caused when current flows to the initiator, which happens when a safing sensor and the deceleration sensor go on simultaneously.



189BE132

3) Rear Side Collision

Electronic safing sensor of the Airbag sensor assembly is designed to be activated by a smaller deceleration rate than the deceleration sensor of the curtain shield airbag sensor assembly. As illustrated below, ignition is caused when current flows to the initiator, which happens when an electronic safing sensor and the deceleration sensor go on simultaneously.

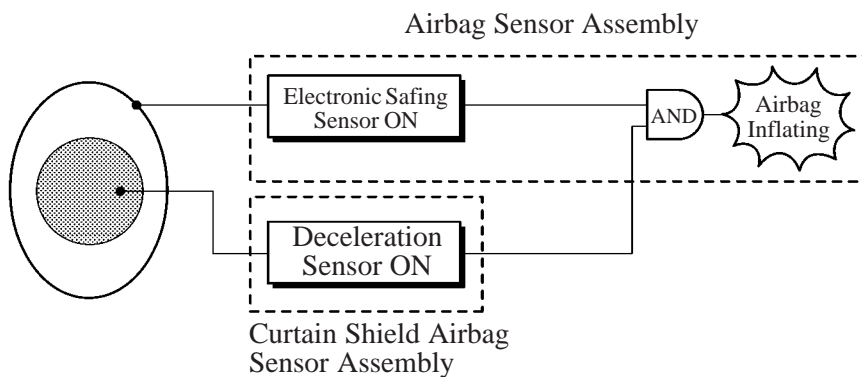

189BE133

2-step Output Front Passenger Airbag Assembly Control

The Airbag sensor assembly detects the extent of the collision in accordance with the signals from the front Airbag sensor assembly. If the collision is extensive, it electrically ignites the initiators “A” and “B” at the same time. Initiator “A” activates the projectile, which tears the bulkhead to discharge the compressed gas mixture. Initiators “A” and “B” burn propellants “A” and “B”, and the heat of the combustion quickly heats and expands the compressed gas mixture. At this stage, the gas mixture is discharged into the airbag at the same pressure curve as in the previous system. If the collision is minor, the system delays the ignition timing of initiator “B” in order to discharge the gas mixture into the airbag at a milder startup pressure curve.

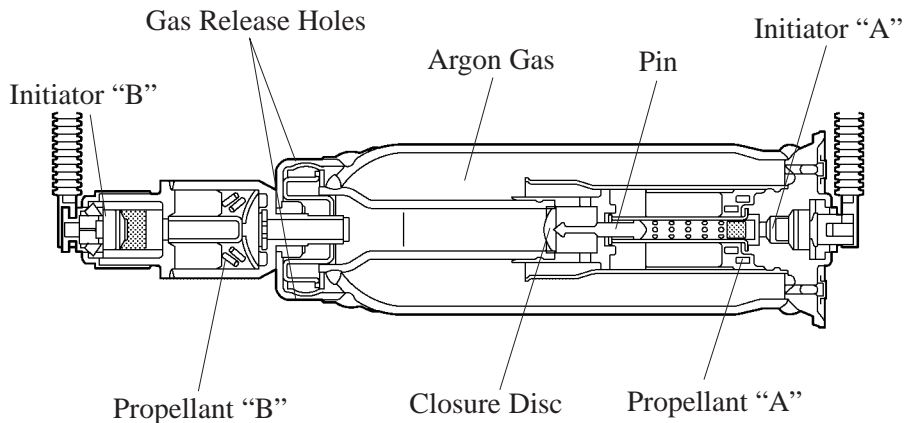

189BE134

► Pressure Curve Imaginary Diagram ◀

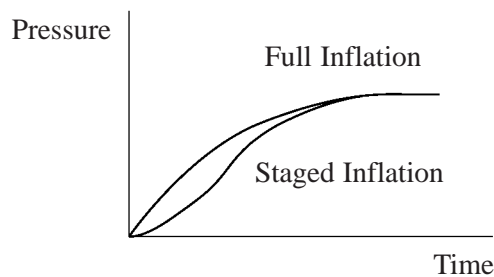

189BE136

BE

Airbag Deployment Prohibition Function

This function uses an occupant detection sensor and front passenger seat belt buckle switch to detect whether or not the front passenger seat is occupied. If the Airbag sensor assembly has determined the front passenger seat is unoccupied, it prohibits the deployment of the front passenger airbags (front and side) and front passenger seat belt pretensioner.