

■ DOOR CLOSER SYSTEM

1. General

- The door closer system is available as a standard on the new LS430.
When the front and rear door closer system detects that the front and rear doors are ajar, it automatically actuates the motors to fully close the front and rear doors.
- Position detection switches are enclosed in the door closer mechanism in each of the front and rear doors lock assemblies to detect whether the front and rear doors are open, closed, or ajar. If a detection signal that indicates that a front and rear doors are ajar is transmitted to the door ECU, the door ECU actuates the operation of the door closer motor in order to fully close the front and rear doors.
- In this system, each door is independently controlled by the door ECU that is provided in the respective door. The door ECUs, which maintain communication via the BEAN (Body Electronics Area Network), belong to the door bus.
- A mechanical cancel mechanism is provided to enable the opening of the front and rear doors by operating either the outside or inside door handle while the door closer system is operating. Through the function of the link and the lever that move together with the movement of the handle when either the outside or inside door handle is operated, the mechanical cancel mechanism cuts off the transmission of the power from the motor in order to disable the operation of the door closer system, thus enabling the door to be opened.
- If the operation of the door closer system is not completed within approximately 3 seconds due to the jamming of a foreign object, the door ECU detects a malfunction and stops the current that is supplied to the motor.

► System Diagram ◀

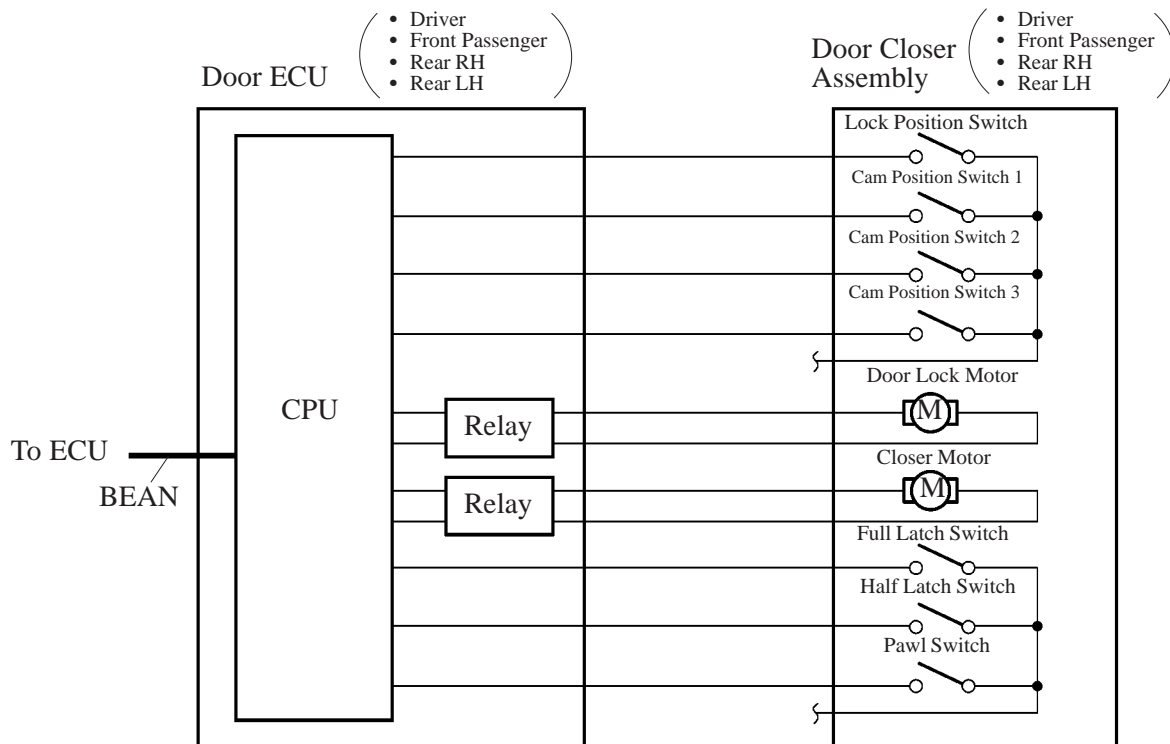

BE

2. Layout of Main Components

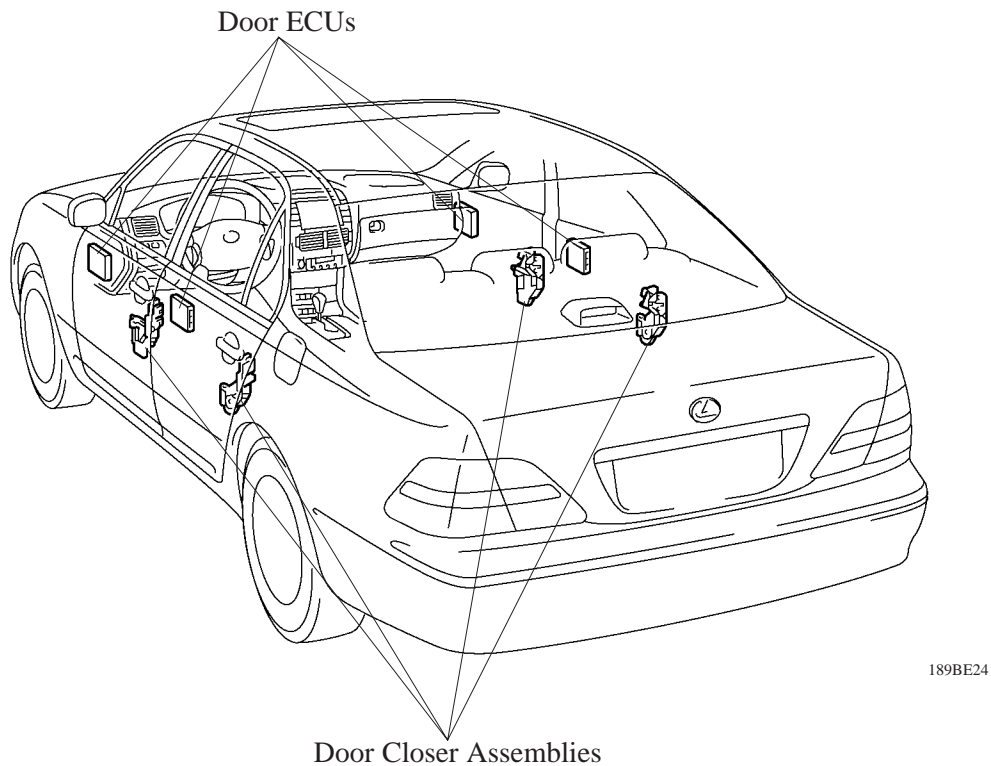

3. Function of Main Components

The door closer system consists mainly of a door closer assembly and the door ECU. Each door closer assembly contains a switch and a motor. The constituent parts perform the functions given in the table below.

Components	Function
Door Closer Assembly	The door closer assembly consists of a door lock mechanism and a closer mechanism. The door lock mechanism performs the operation of a normal door lock. The closer mechanism transmits the rotational movement of the door closer motor via the lever and the latch to fully close the front and rear doors that is ajar.
Pawl Switch	The changes in the engagement of the striker pole with the latch are detected by the ON or OFF signal of the switch, which is then transmitted to the door ECU.
<ul style="list-style-type: none"> • Full Latch Switch • Half Latch Switch 	Whether the latch is fully latched or half latched is detected in accordance with the rotating position of the latch, and a signal is transmitted to the door ECU.
<ul style="list-style-type: none"> • Cam Position Switch 1 • Cam Position Switch 2 • Cam Position Switch 3 	The rotating position of the closer motor is detected by the ON/OFF pattern of the three switches and an appropriate signal is transmitted to the door ECU.
Lock Position Switch	Detects whether the door is locked or unlocked and transmits a signal to the door ECU.
Closer Motor	Actuated by the signals from the door ECU, this motor rotates the latch from the half-latched to the full-latched state.
Door Lock Motor	Actuated by the signals from the door ECU, this motor moves a link to lock or unlock the door.
Door ECU	Controls the door closer system in accordance with the signals from the switches that are provided in the door closer assembly.

4. Construction and Operation

Door Closer Assembly

- The door closer assembly consists of the door lock mechanism that performs the ordinary door lock control, and a closer mechanism that performs door closer control. In addition, the assembly contains a pawl switch, full latch switch, half latch switch, closer motor, and door lock motor.
- The cam position switches (1 to 3) that detect the rotation position of the closer motor are enclosed in the closer motor. The lock position switch is integrated with the base of the door lock active lever.

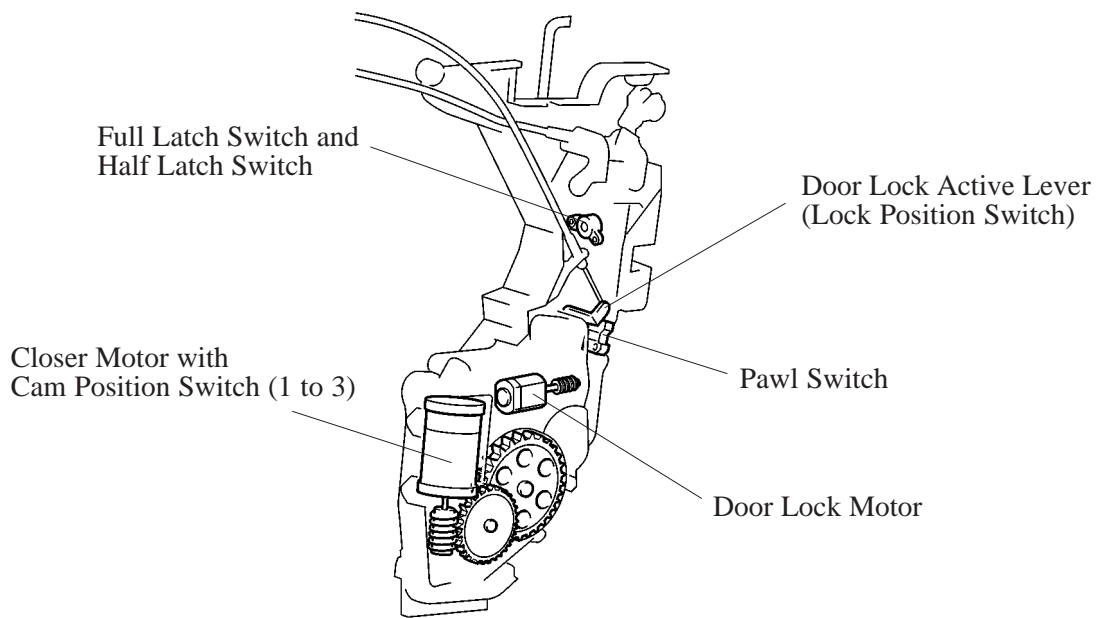

LH Side

189BE25

Door ECU

1) General

- In the door closer system, the transition of the door from the open state to the ajar state is detected by the door ECU. The ECU then actuates the closer motor to rotate the latch in order to fully close the door. This ECU, which is provided in each of the doors, independently controls the respective door. The door ECUs, which maintain communication via the BEAN, belong to the door bus.
- When the system is activated, if the door ECU detects an abnormal condition, it outputs the applicable DTCs (Diagnostic Trouble Codes). The DTCs can only be accessed through the use of a LEXUS hand-held tester.

2) Operation

The timing chart below shows the basic operation of the door closer system.

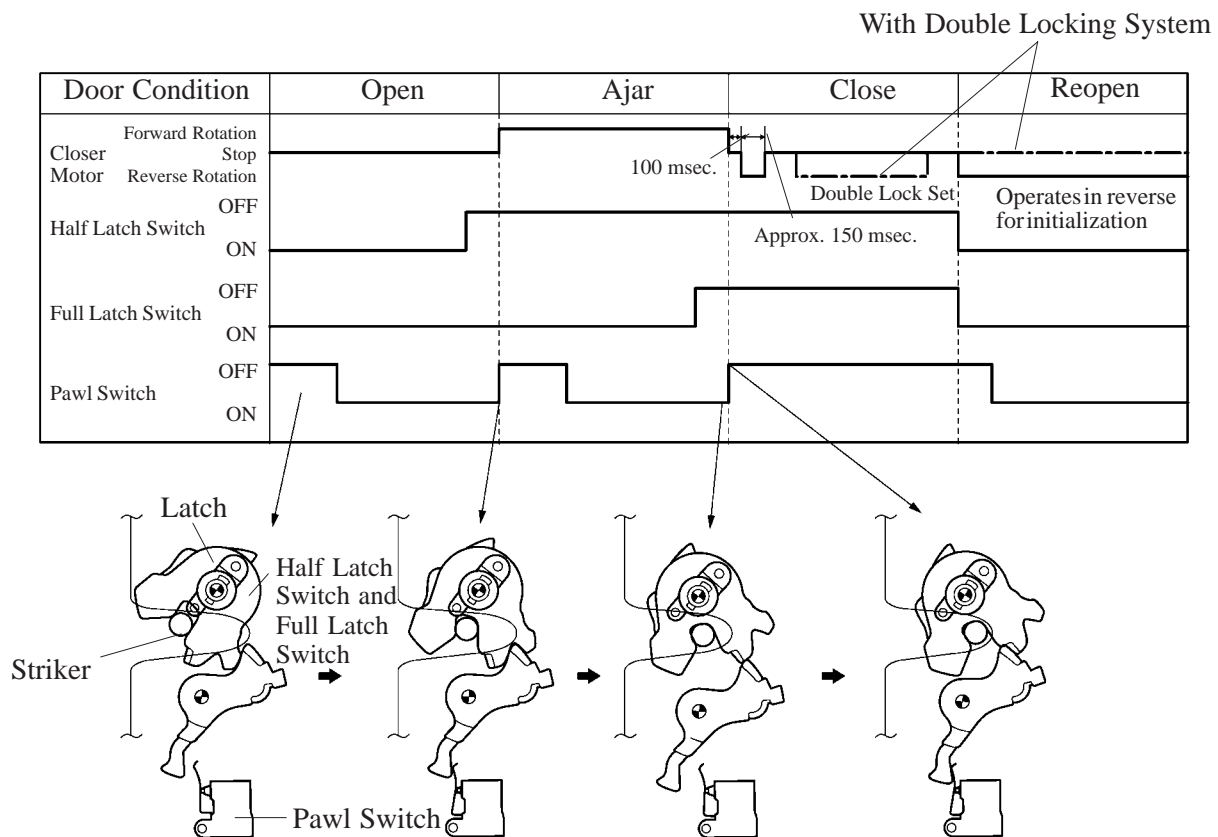

189BE33

This state continues for 0.3 seconds; then, the closer motor operates in order to transfer to the fully closed state.

- To prevent the latch from making excess travel, after 100 msec have elapsed from the time the closer motor has stopped, the closer motor operates in reverse for approximately 150 msec.
- On the models with a double locking system, the closer motor returns to its neutral state after the double lock has been set.

NOTE: If an attempt is made to activate the door closer system with the inside or outside door handle pulled, the system will not activate.

3) Cancel Function

- In the door closer system, operating the inside or outside door handle causes the link between the latch and the closer motor to separate. This cancels the system and allows the door to be opened regardless of the state of the system.
- For example, if the system is operating from the half latched state to the fully latched state, the actuation force of the motor causes the latch lever to push and turn the latch so that the striker can be pulled in by the latch.

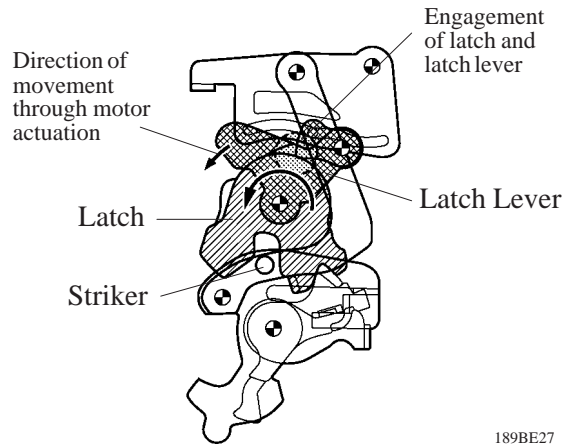

- While the closer system is activated, operating the inside or outside door handle causes the latch lever and latch to become disengaged. This frees the latch, allowing the door to open.

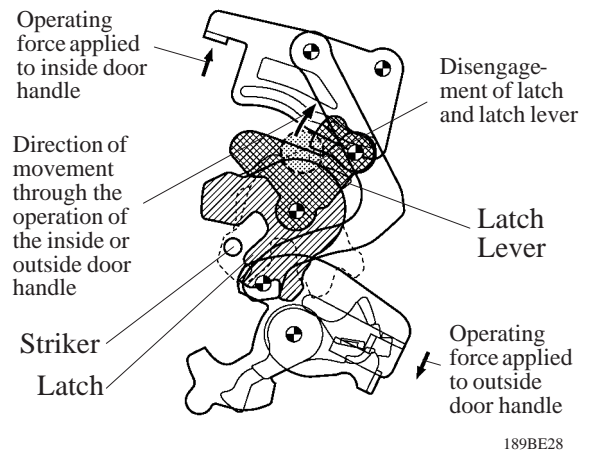

NOTE: If the child lock of a rear door is engaged, it cannot be canceled by operating the inside door handle.

4) Closer Motor

- The rotating position of the closer motor is defined by the three segments of the motor's moving range in accordance with the ON/OFF patterns of the three cam position switches (1 to 3) that are provided in the closer motor.

Segment	1	2	3
Cam Position Switch 1	OFF	ON	ON
Cam Position Switch 2	ON	ON	OFF
Cam Position Switch 3	OFF	OFF	OFF

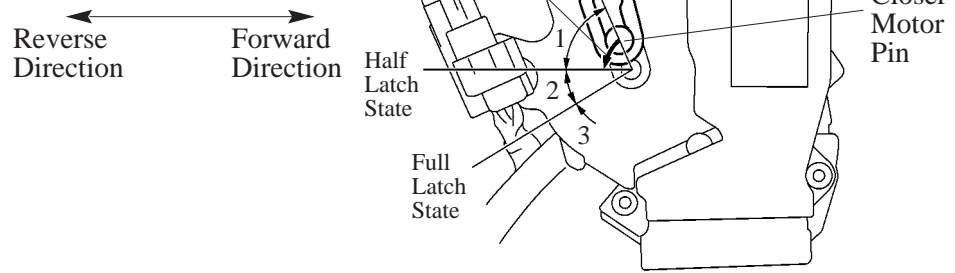

189BE29

- If the door ECU detects an abnormal condition while the closer motor is operating, the ECU stops the closer motor and outputs an applicable DTC (Diagnostic Trouble Code). See the LEXUS LS430 Repair Manual (Pub. No. RM792E) for the method for checking the DTCs, for clearing the DTCs, and details on the DTCs.

5) Fail-Safe

The door ECU stops the system if it detects a malfunction in the system. However, the doors can be opened or closed manually even if the closer system is not operating.