

## ■ CONSTRUCTION AND OPERATION

### 1. Air Conditioner Control Panel

#### General

- As in the previous model, an easy-to-use, push-button type center cluster panel is used for the front air conditioner control model. There are two types of control panels, depending on the setting of the multi-display.
- An audio and rear air conditioner control switch that is integrated with the audio control switch is provided on the rear air conditioner control panel.

#### Center Cluster Panel

- An temperature control switch for the driver and front passenger areas is provided in the instrument panel to improve the ease of use.
- On the models without a multi-display, the air conditioner status is displayed on an LCD (Liquid Crystal Display) panel. On the models with a Multi display, the air conditioner status is displayed through the on-screen function on the Multi display.
- The operating signals from the center cluster panel are input in the air conditioner ECU via the BEAN (Body Electronics Area Network).

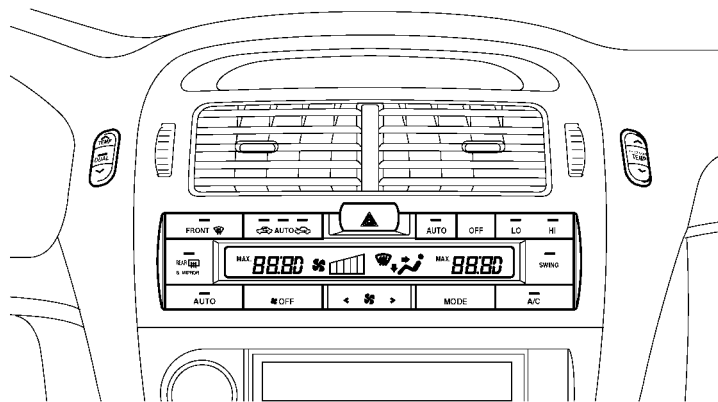

without Multi Display

189BE101

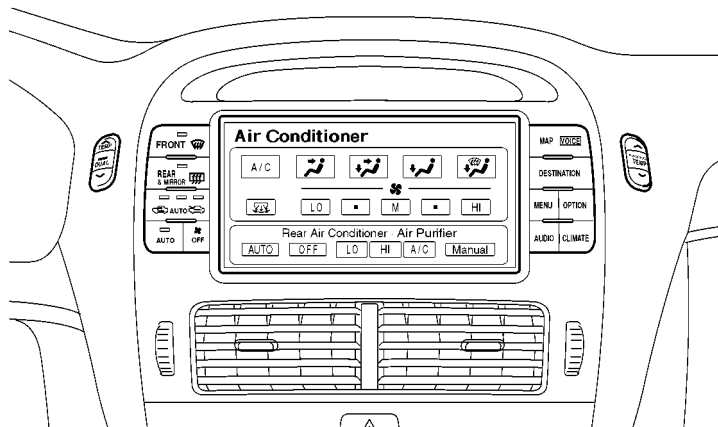

with Multi Display

189BE102

**Audio and Rear Air Conditioner Control Switch**

- This control switch uses an LCD (Liquid Crystal Display) to ensure excellent visibility.
- The operating signals from this control switch are input in the Gateway ECU via the AVC-LAN (Audio Visual Communication – Local Area Network). The Gateway ECU then converts these signals into BEAN signals, which are then input in the air conditioner ECU.

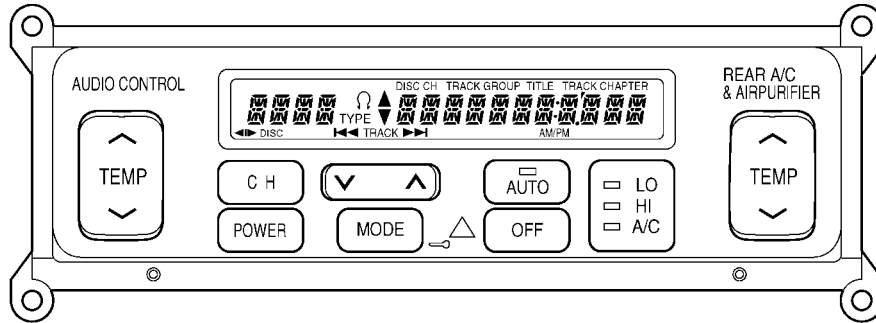

189BE103

## 2. Air Conditioner Unit

### General

- As in the previous LS400, the air conditioner unit in which the evaporator and the heater core are located in front of the vehicle, continues to be used. This unit realizes independent right/left temperature control for the driver and front passenger through the use of a film damper as in the previous model.
- A compact, brushless blower motor with a built-in control circuit has been newly adopted.
- A multi-tank, super-slim structure evaporator has been newly adopted.

### Blower Fan

A large-diameter, small-width blower fan, and a compact, brushless blower motor with a built-in control circuit have been adopted to provide a larger footwell space for the front passenger.

FET (Field Effect Transistor)

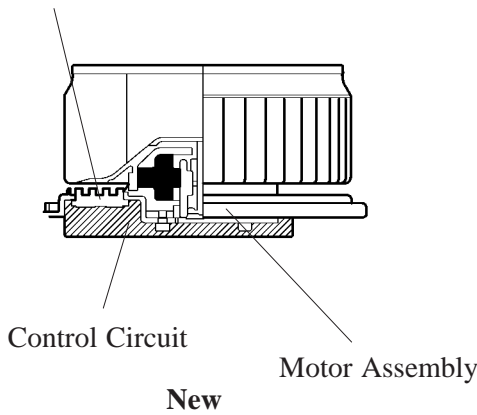

177BE13

Brush

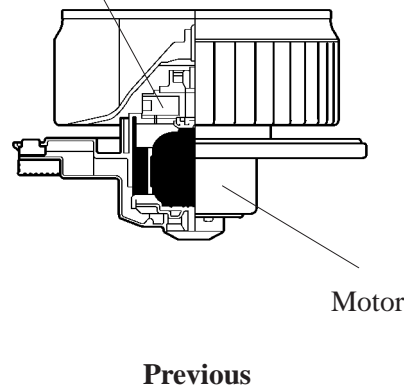

177BE14

### Evaporator

By placing the tanks at the top and the bottom of the evaporator unit and by adopting an inner fin construction, the heat exchanging efficiency has been improved and the evaporator unit's temperature distribution has been made more uniform. As a result, it has become possible to realize a thinner evaporator construction. Furthermore, the evaporator body has been coated with a type of resin that contains an antibacterial agent in order to minimize the source of foul odor and the propagation of bacteria.

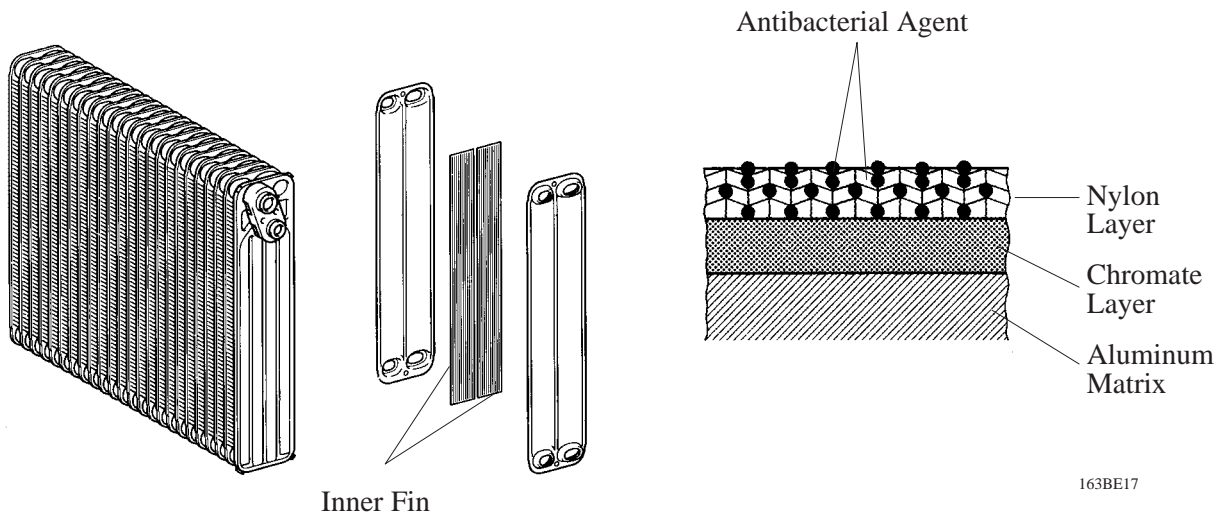

163BE17

### 3. Condenser

#### General

The new LS430 has newly adopted sub-cool condenser in which a multi-flow condenser (consisting of two cooling portions: a condensing portion and a super-cooling portion) and a gas-liquid separator (modulator) have been integrated. This condenser has adopted the sub-cool cycle for its cooling cycle system to improve the heat exchanging efficiency.

#### Sub-Cool Cycle

In the sub-cool cycle of the sub-cool condenser that has been adopted, after the refrigerant passes through the condensing portion of the condenser, both the liquid refrigerant and the gaseous refrigerant that could not be liquefied are cooled again in the super-cooling portion. Thus, the refrigerant is sent to the evaporator in an almost completely liquefied state.

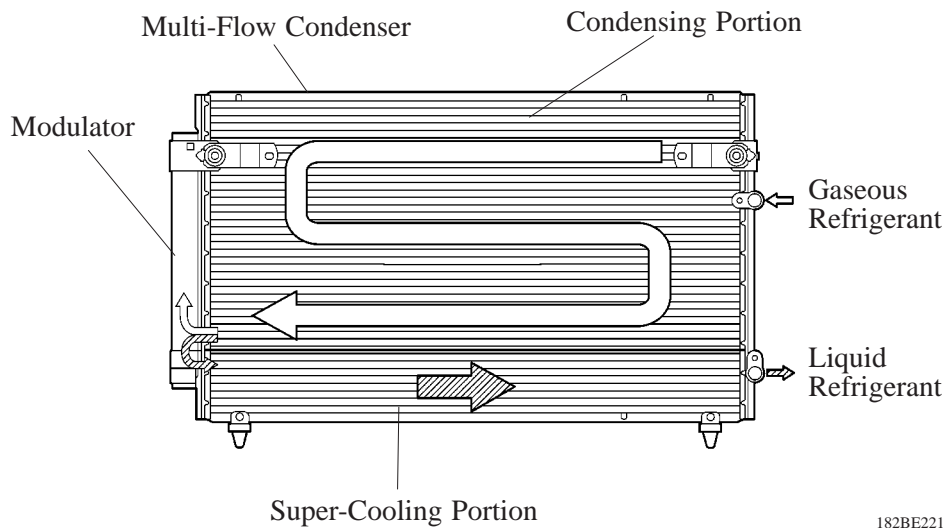

**BE**

**NOTE:** The point at which the air bubbles disappear in the refrigerant of the sub-cool cycle is lower than the proper amount of refrigerant with which the system must be filled. Therefore, if the system is recharged with refrigerant based on the point at which the air bubbles disappear, the amount of refrigerant would be insufficient. As a result, the cooling performance of the system will be affected.

For the proper method of verifying the amount of the refrigerant and to recharge the system with refrigerant, see the LEXUS LS430 Repair Manual (Pub. No. RM792E).

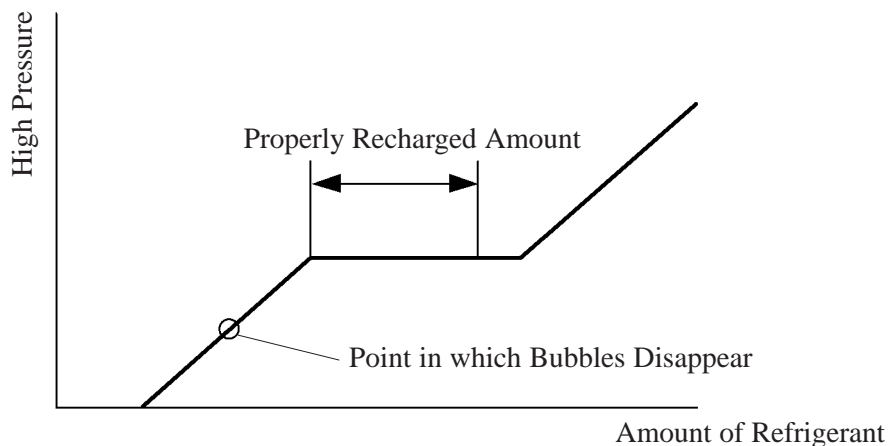

## 4. Compressor

### General

On all models except those for the G.C.C. countries, the compressor has been changed from the 10PA20 type to the 7SBU16 type. This is a continuously variable capacity type compressor in which its capacity varies in accordance with the cooling load of the air conditioner. A solenoid control valve that adjusts the suction pressure so that the suction pressure can be controlled as desired is provided.

### Construction

When the magnetic clutch is turned ON and the shaft rotates, this movement is transmitted via the lug plate that is connected to the shaft to rotate the swash plate. This rotational movement of the swash plate is transmitted via the shoe to the reciprocal movement of the piston in the cylinder, which performs the suction, compression, and discharge of the refrigerant.

The control for varying the compressor capacity is effected in the following manner: Based on the changes in pressure that occur in the low-pressure side in accordance with the cooling load, the control valve regulates the swash plate chamber's internal pressure to vary within the low-to medium pressure range. This change of pressure changes the swash plate angle, varies the piston stroke, and changes the amount of refrigerant that is discharged.

Furthermore, by varying the control amperage applied to the solenoid control valve, the discharge capacity control range can be widened by steplessly varying the pressure in the low pressure side, in order to improve air conditioner performance and energy savings.

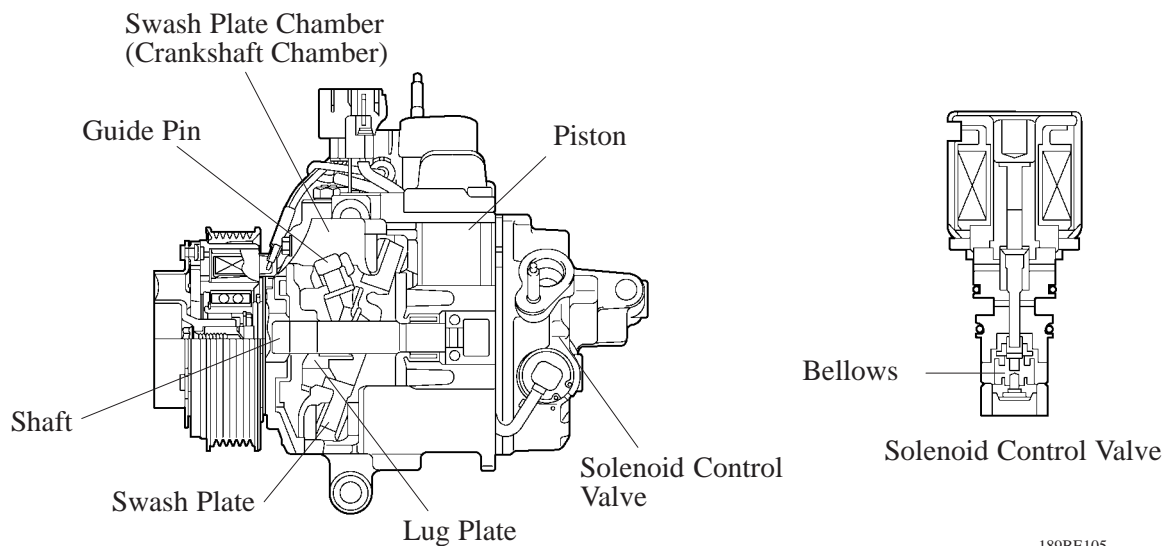

189BE105

**Operation**

**1) When the cooling load is large (interior temperature is high), operating at 100% capacity:**

When the cooling load becomes large and the pressure in the low-pressure side increases, the air conditioner ECU outputs signals to the solenoid control valve in accordance with the signals from the evaporator temperature sensor. This causes the bellows to contract, the valve to close, and the valve to close between the high-pressure chamber and the swash plate chamber. As a result, the internal pressure in the swash plate decreases gradually, causing the internal pressure in the swash plate and the pressure of the low-pressure side to ultimately reach equilibrium.

At this time, the compound force (consisting of the pressure of the low-pressure side, and the reaction force from the lug plate) that is applied to the left side of the piston becomes lower than the internal pressure of the cylinder that is applied to the right side of the piston. Therefore, the piston moves towards the left, causing the tilt of the swash plate to increase. Accordingly, the amount of piston stroke increases, and when the piston stroke is at its maximum (when the tilt of the swash plate is at its maximum), the compressor operates at its 100% capacity.

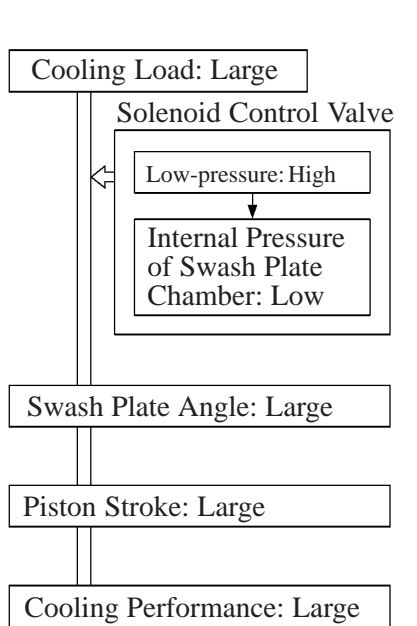

189BE106

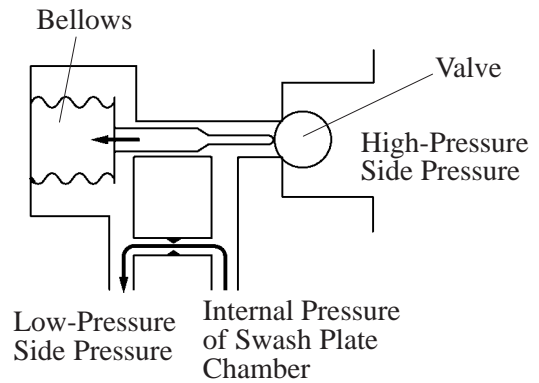

152BE30

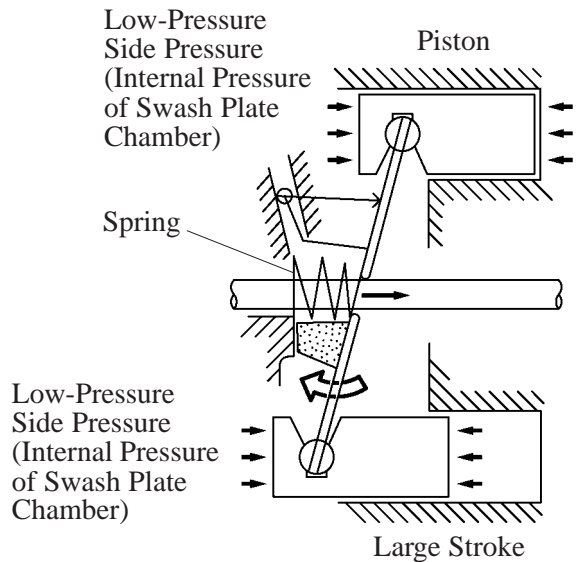

152BE31

2) When the cooling load is small (interior temperature is low)

When the cooling performance is low and the pressure of the low-pressure side decreases, the ECU outputs signals to the solenoid control valve in accordance with the signals from the evaporator temperature sensor. This causes the bellows to expand, the valve to open, and the valve between the high-pressure chamber and the swash plate chamber to open. As a result, the pressure of the high-pressure side is introduced into the swash plate chamber, causing the pressure in the swash plate chamber to increase. Therefore, the compound force (consisting of the pressure in the swash plate chamber) and the reaction force from the lug plate) that is applied to the left side of the piston becomes higher than the internal pressure of the cylinder that is applied to the right side of the piston. Then, the piston moves to the right, causing the tilt of the swash plate to decrease. As a result, the piston stroke becomes shorter and the amount of refrigerant that is discharged becomes smaller. As the rotational resistance decreases in this manner, the engine load is reduced and fuel economy is improved.

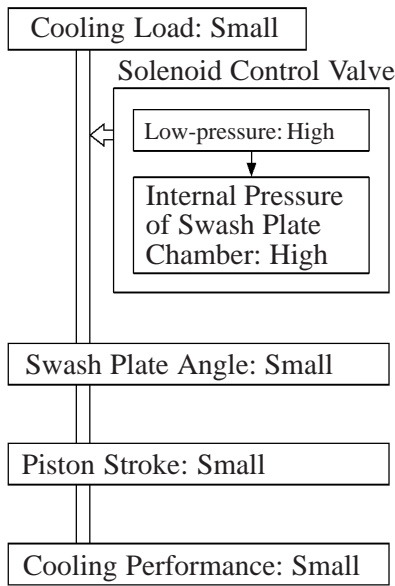

189BE106

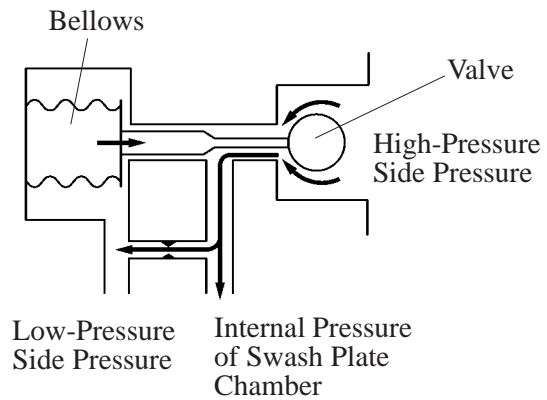

152BE32

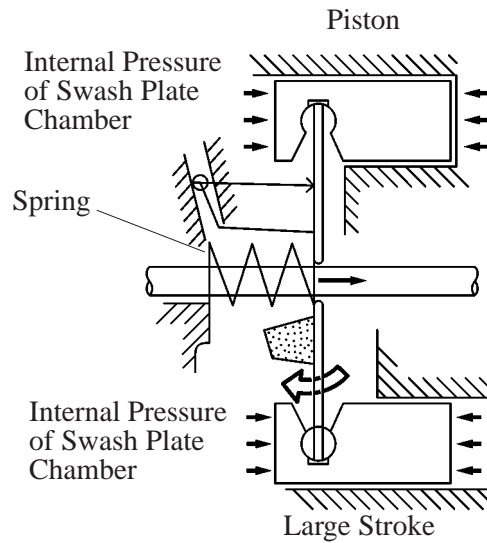

152BE33

## 5. Clean Air Filter

### General

- A deodorizing function that removes the exhaust gas smell has been added to the clean air filter in the front air conditioner.
- The clean air filter in the rear air conditioner and air purifier has the air purifier function of removing the smell of tobacco smoke or other odors from the cabin.

### Clean Air Filter (for Front Air Conditioner)

- A deodorizing function that eliminates the exhaust gas smell that enters the cabin from the outside has been added to the conventional clean air filter. This clean air filter uses spreading type activated charcoal in the deodorizing layer to eliminate the exhaust gas smell.
- The air conditioner ECU determines the replacement interval of this filter based on the airflow volume at the inlets (for fresh air and recirculation air), and indicates it on the multi-information display in the combination meter.

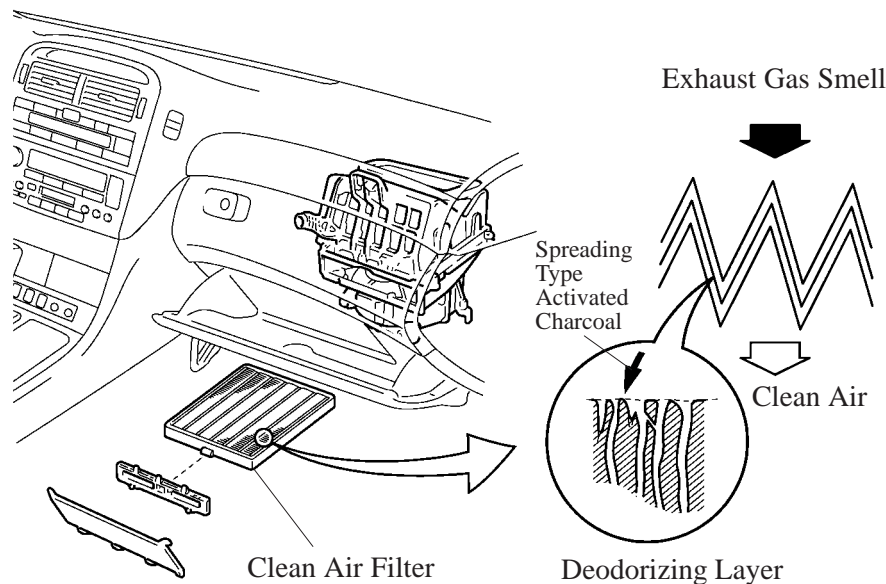

189BE107

### Service Tip

- The replacement interval for the clean air filter is when indicated on the multi-information display in the combination meter.

#### [Procedure After Replacing the Clean Air Filter]

Press the OFF button on the center cluster panel for 4 seconds or longer to reset the filter clogging judgment value. To inform the driver that the reset has been completed, the buzzer sounds and “A/C FILTER RE-SET” appears on the display. If the above operation is performed before the message is displayed, the judgment value becomes reset at that point. Therefore, make sure to observe the following order: message display → filter replacement → operation described above.

- Do not wash the clean air filter with water or use an air blower to clean it because the clean air filter contains spreading type activated charcoal.



### Clean Air Filter (for Rear Air Conditioner and Air Purifier)

This filter, which contains highly charged electret fibers and activated charcoal, provides an air purification function in addition to removing dust.

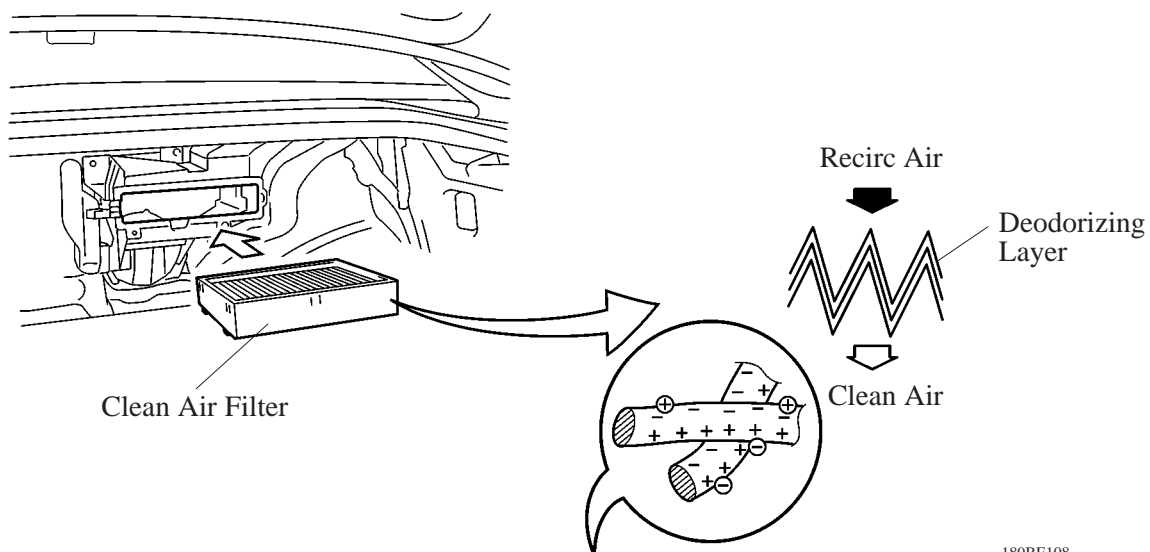

189BE108

#### Service Tip

Replace the clean air filter when the performance of air flow or deodorant function becomes low by the deterioration of filter.

## 6. Air Conditioner ECU

### General

The air conditioner ECU has following control.

Control	Outline
Neural Network Control	This control is capable of effecting complex control by artificially simulating the information processing method of the nervous system of living organisms in order to establish a complex input/output relationship that is similar to a human brain.
Outlet Air Temperature Control	In compliance with the temperature set at the temperature control switch, the neural network control calculates the outlet temperature based on the input signals from various sensors. In addition, corrections in accordance with the signals from the evaporative temperature sensor and the water temperature sensor are added to control the outlet air temperature.
Blower Control	Controls the front and rear blower motors in accordance with the airflow volume that has been calculated by the neural network control based on the input signals from various sensors.
Air Outlet Control	Automatically switches the outlets in accordance with the outlet mode ratio that has been calculated by the neural network control based on the input signals from various sensors.
Air Inlet Control	Automatically controls the air inlet control damper in accordance with the airflow volume that has been calculated by the neural network control.
Compressor Control*1	Controls the compressor to turn ON/OFF and the discharge capacity based on the signals from various sensors.
Outer Temperature Indication Control	Based on the signals from the ambient temperature sensor, this control calculates the outside temperature, which is then corrected in the air conditioner ECU, and shown in the multi-information display in the combination meter.
Rear Window Defogger Control	Switches the rear defogger and outside rear view mirror heaters on for 15 minutes when the rear defogger switch is switched on. Switches them off if the switch is pressed while they are operating.
Intelligent Swing Register Control	Controls the orientation and the angle of the front center register based on the input signals from various sensors and on the outlet mode.
Clean Air Filter Clogging Judgment	Determines whether the clean air filter (for the front A/C) is clogged by monitoring the air inlets, and airflow volume.
Automatic Recirculation Control	The A/C ECU automatically controls the air inlets based on the signals from the smog ventilation sensor.
Air Quality Control*2	Improves the air quality by linking the air inlet control damper and the blower motor (for the rear A/C and air purifier), based on the signals from the exhaust gas sensor and the smoke sensor.
Self-diagnosis	Checks the sensors in accordance with operation of the air conditioner switches, then clock display a DTC (Diagnosis Trouble Code) to indicate if there is a malfunction or not (sensor check function).
	Drives the actuators through a predetermined sequence in accordance with the operation of the air conditioner switches (actuator check function).

\*1: Except G.C.C. Countries Model

\*2: with Rear Air Conditioner and Air Purifier

BE

### Neural Network Control

The neural network control consists of neurons in the input layer, intermediate layer, and output layer. The input layer neurons process the input data of the outside temperature, the amount of sunlight, and the room temperature based on the outputs of the switches and sensors, and output them to the intermediate layer neurons. Based on this data, the intermediate layer neurons adjust the strength of the links among the neurons. The sum of these is then calculated by the output layer neurons in the form of the required outlet temperature, solar correction, target airflow volume, and outlet mode control volume. Accordingly, the air conditioner ECU controls the servo motors and blower motors in accordance with the control volumes that have been calculated by the neural network control.

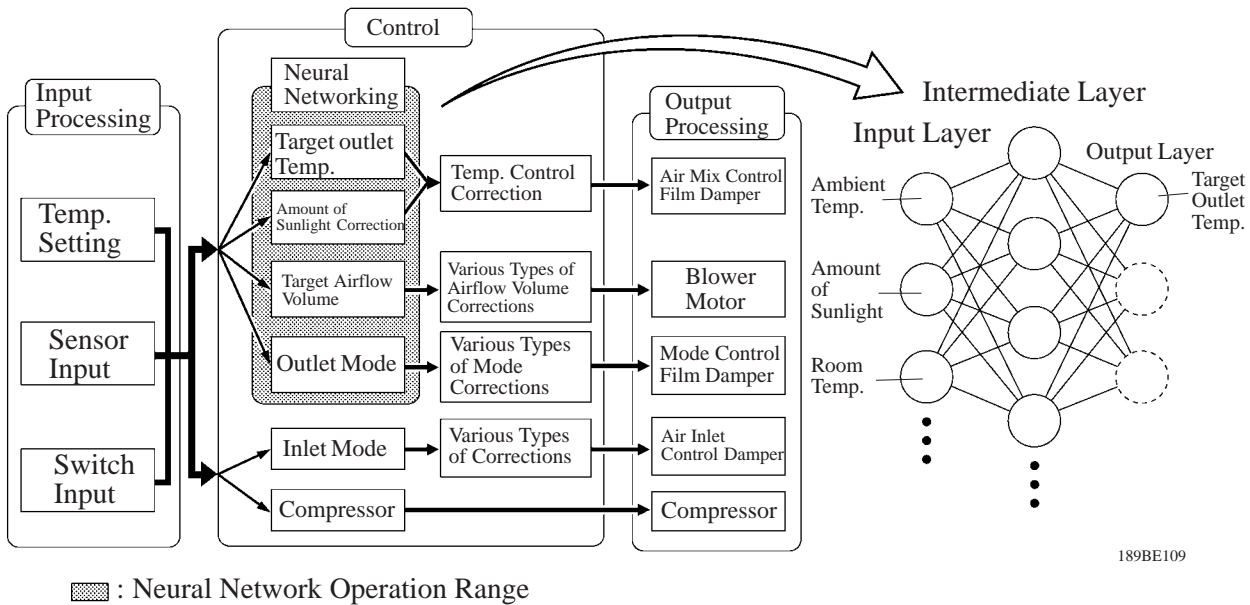

189BE109

### Intelligent Swing Register Control

#### 1) General

Based on the temperature setting and the signals from the room temperature sensor, solar sensor, and the occupant detection sensor, the air conditioner ECU controls the orientation and the angle of the front center register.

#### ► System Diagram ◀

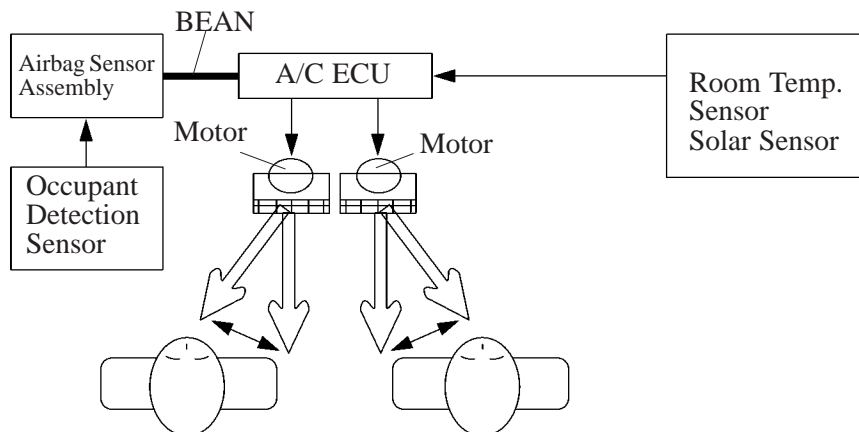

189BE110

2) Operation

During the initial stages of cooling down or warming up, control is effected to direct the airflow to the occupants to improve the feel of cooling or heating. When the temperature in the cabin becomes stabilized, the register swings gradually so that the airflow is directed away from the occupants.

► Imaginary Diagram ◀

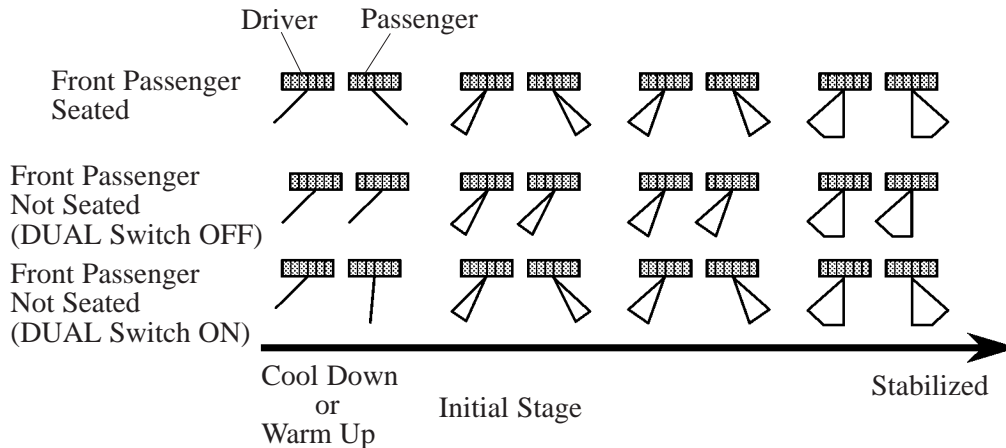

189BE111

Clean Air Filter Clogging Judgment

The airflow volume decreases when the filter becomes clogged, making the system susceptible to insufficient cooling or heating.

Although the replacement intervals for the clean air filter were previously indicated in the manuals, it could not be readily discerned when a filter was last replaced, or when it should be replaced next. On the new model, the multi-information display in the combination meter informs the driver by indicating that the filter has become clogged, in order to improve serviceability.

In this system, the A/C ECU constantly monitors the inlet mode and current airflow volume, in order to forecast the clogging of the clean air filter. When the ECU determines that the filter has become clogged, it indicates “CHANGE A/C FILTER” on the multi-information display in the combination meter.

► System Diagram ◀

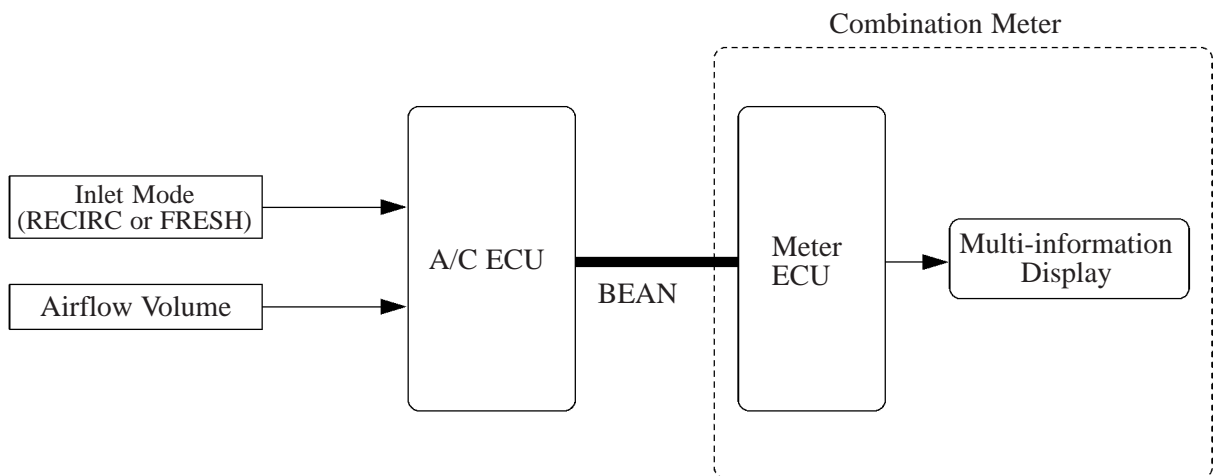

189BE112

## Automatic Recirculation Control (Except G.C.C. Countries Model)

### 1) General

The automatic recirculation system is a system which uses a smog ventilation sensor which detects harmful elements such as CO, HC, and NO<sub>x</sub> which are present in the air outside of the vehicle, and automatically switches the air inlet modes in accordance with the level of concentration of those elements.

#### ► System Diagram ◀

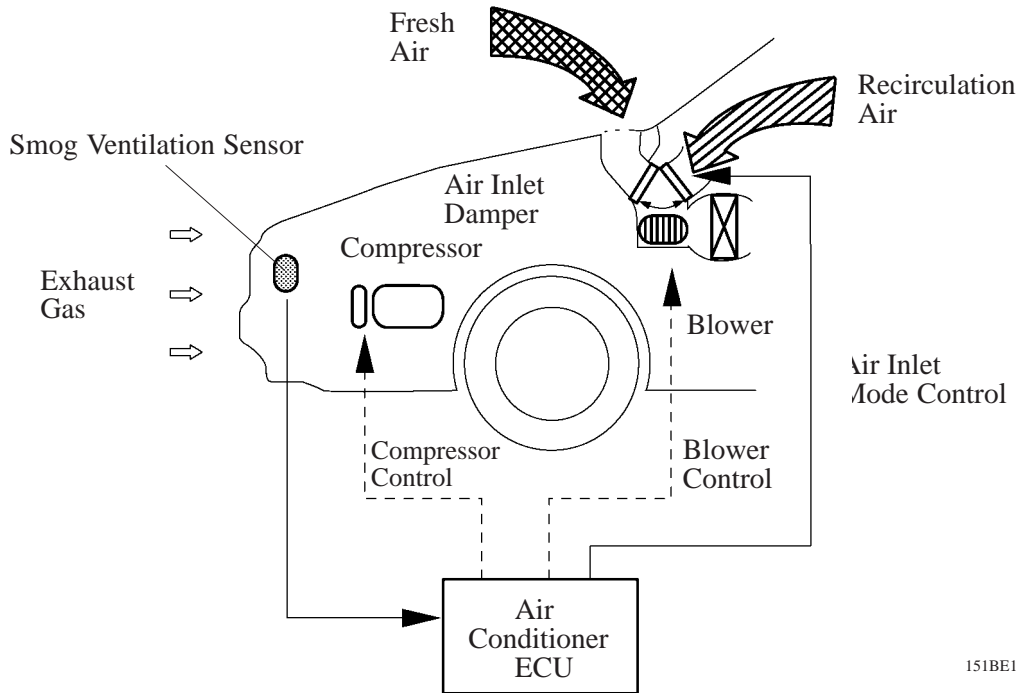

151BE17

### 2) Operation

#### a. Normal Operation

When the air inlet mode is selected in the automatic mode, the air conditioner ECU automatically switches the air inlet to the recirculation mode or to the fresh air mode by making a comprehensive analysis for preventing the intrusion of the harmful elements (CO, HC, NO<sub>x</sub>) that are present in the exhaust gases that are contained in the air outside of the vehicle, thus ensuring the maximum cooling performance in the summer and preventing the fogging of the windows in the winter. Also, when the automatic mode is selected, the air conditioner ECU automatically turns ON the compressor. However, to allow for the smog ventilation sensor to warm up, the automatic switching of the air inlet modes through the detection of the elements is not carried out for 30 seconds immediately after the engine is started.

**b. Automatic Internal Air Cool Down Operation**

When the air inlet mode is in the automatic mode and the vehicle's internal air temperature is high, such as in summer, the air conditioner ECU switches the air inlet mode to the recirculation mode in order to reduce the internal air temperature.

**c. Automatic External Air Fogging Prevention Operation**

When the air inlet mode is in the automatic mode and the blower or the compressor is turned OFF through the manual operation of the switch or through automatic control, the air conditioner ECU switches the air inlet mode to the fresh air mode.

When the outside air temperature is low, the air conditioner ECU automatically switches the air inlet mode to the fresh air mode in order to ensure the defogging performance of the window.

- NOTE:**
- The smog ventilation sensor cannot detect elements such as the smoke from a bonfire or factory exhaust, foul or animal odors, and dirt or dust particles. Therefore, the air inlet modes are not switched in accordance with those elements.
  - Depending on the direction of the wind, the smog ventilation sensor might not be able to detect the exhaust gas elements, and could emit an odor.

**Air Quality Control (Except G.C.C. Countries Model)**

This control, which is linked to the automatic recirculation control, operates the rear air conditioner and air purifier blower motor to improve the efficiency of the air purifier in order to supply the vehicle cabin with good quality air.

► **System Diagram** ◀

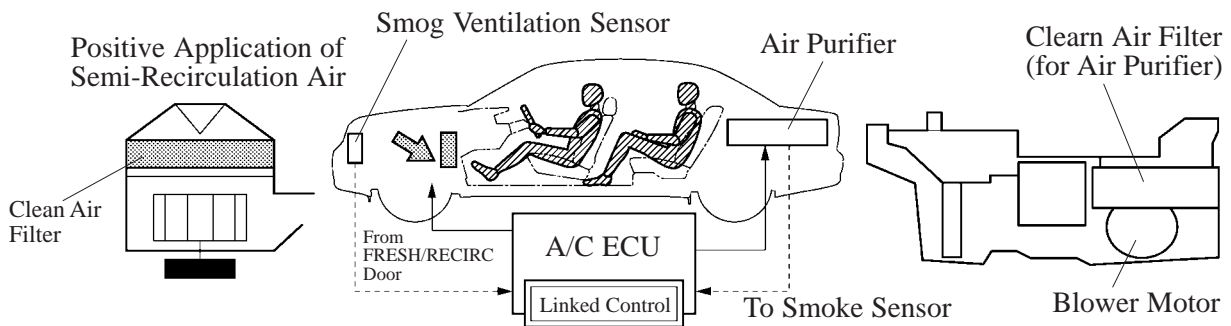

BE

► **Effectiveness** ◀

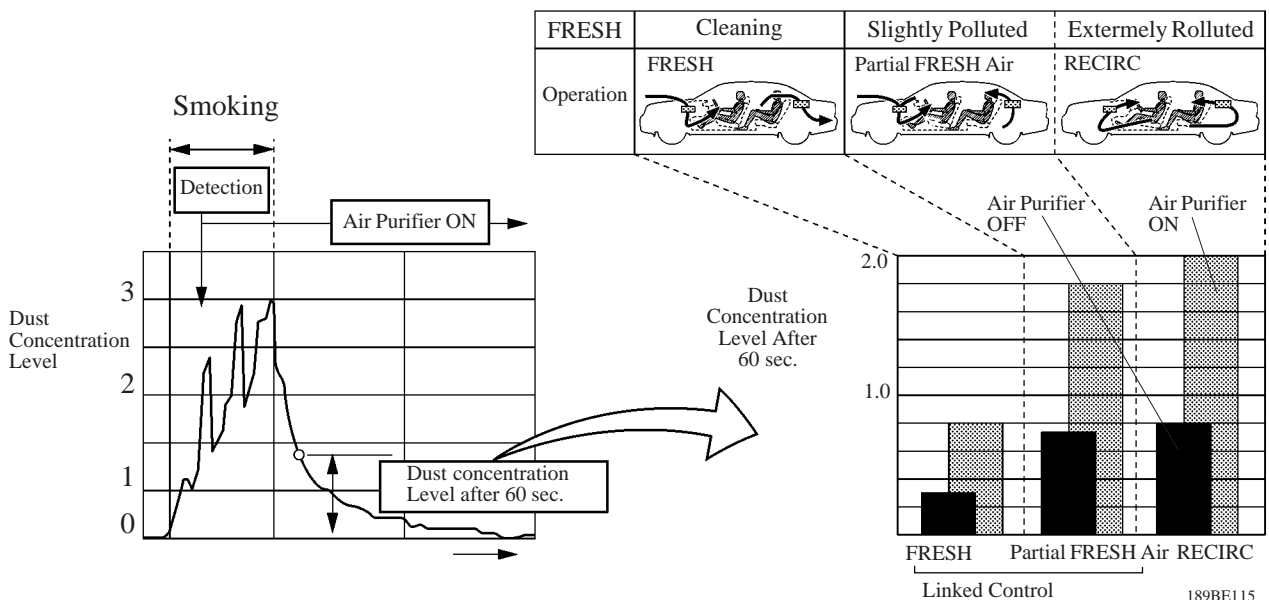

189BE113

189BE115

## Self-Diagnosis

- The air conditioner ECU has a self-diagnosis function. It stores any operation failures in the air conditioner system memory in the form of a malfunction code. By operating switches on the air conditioner control switches, the stored malfunction code will be indicated. Since diagnostic results are stored directly by electric power from the battery, they are not cleared even when the ignition switch is turned off.

### ► Functions ◀

Function	Outline
Indicator Check	Checks indicator lights and temperature setting display.
Sensor Check	Checks the past and present malfunctions of the sensors, and clearing the past malfunction data.
Actuator Check	Checks against actuator check pattern if blower motor, servo motors and magnetic clutch are operating correctly according to signals from ECU.

- The check functions can be started by the following procedure shown below.

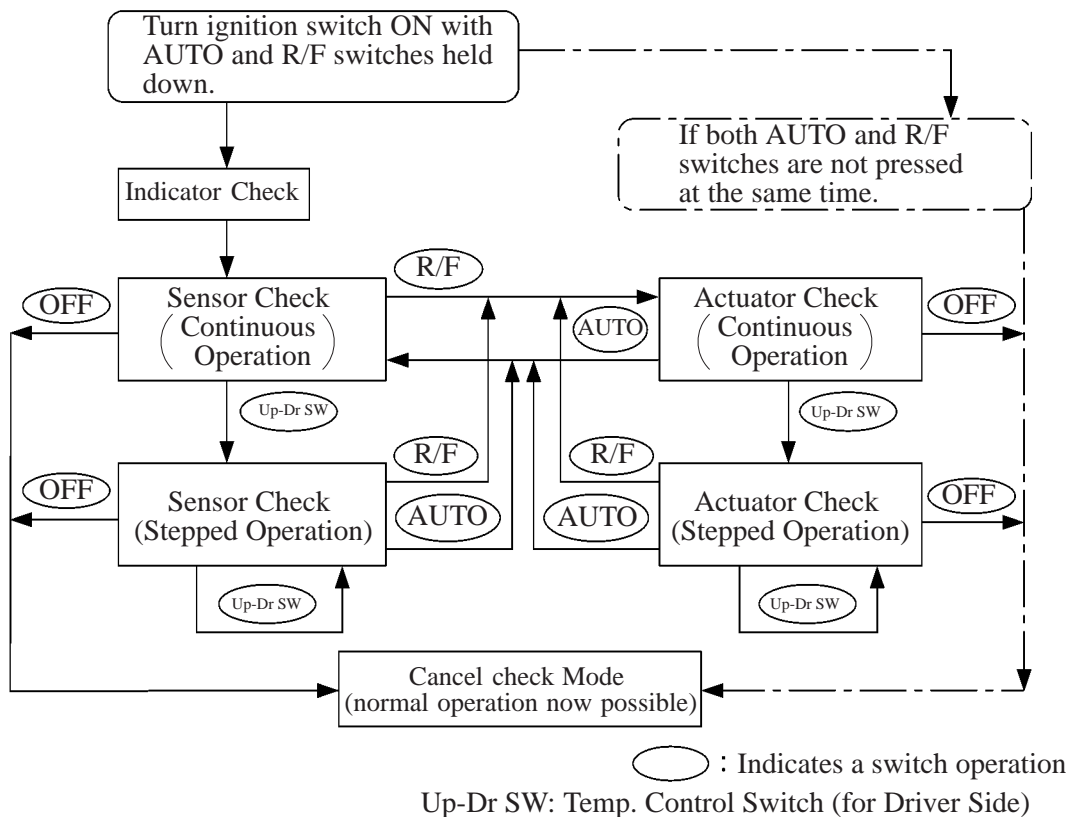

187BE33

For details on the indicator check, sensor check, actuator check function, and clearing of this system, refer to the LEXUS LS430 Repair Manual (Pub. No. RM792E).