

■ AUTOMATIC HEADLIGHT BEAM LEVEL CONTROL SYSTEM

1. General

The automatic headlight beam level control system regulates the orientation of the reflectors of the headlights in relation to the posture of the vehicle that has been detected by sensors. Thus, it is a system that maintains the headlight beams to a constant level while the vehicle is being driven.

The basic operation and construction are the same as in the previous system.

► System Diagram ◀

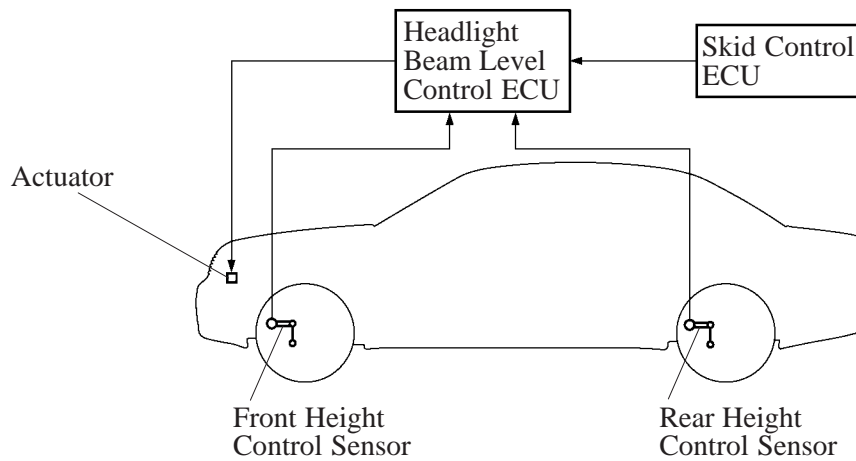

189BE61

2. Layout of Component

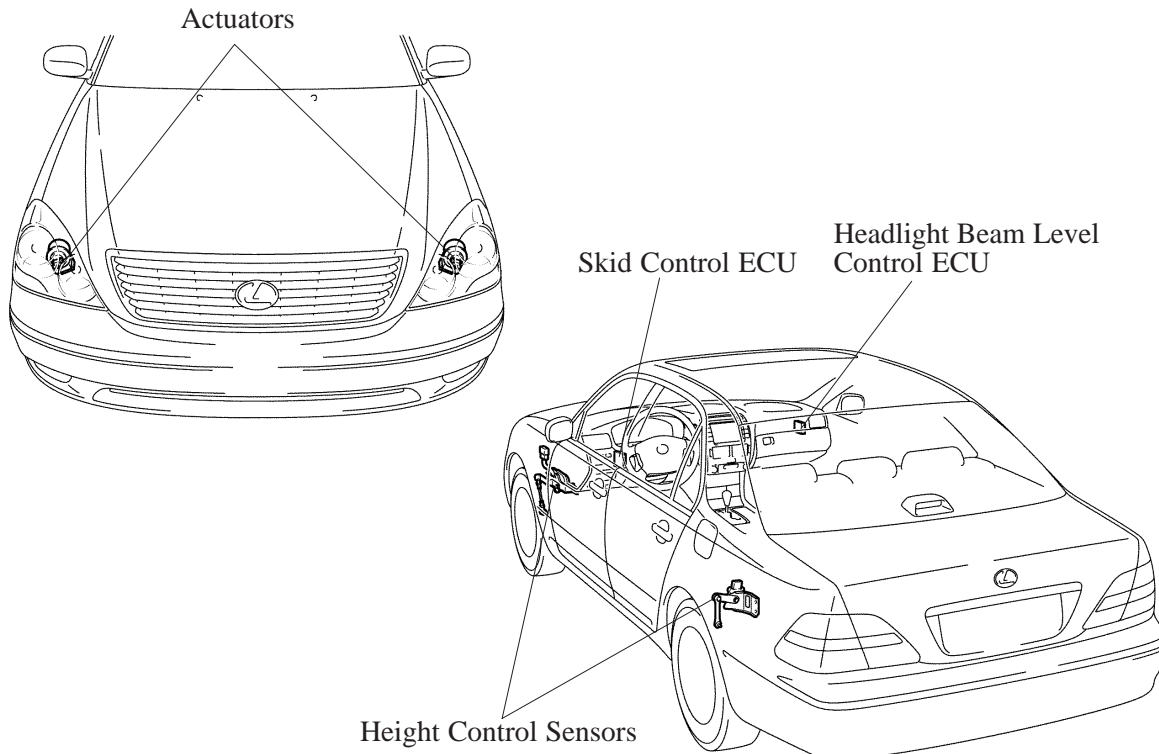

189BE43

3. Construction

Headlight Beam Level Control ECU

Based on the signals that are transmitted by the height control sensors and the skid control ECU, this ECU detects the amount of variance of the vehicle posture.

Based on the detected value, this ECU outputs control signals to the actuator.

The headlight beam level control ECU provides initial set control and fail-safe function.

Height Control Sensor

The height control sensors detect the amount of variance of the vehicle height while the vehicle is being driven, and output this amount in the form of signals to the headlight beam level control ECU. Both of these sensors are located in the left side suspension, one in the front suspension, and the other in the rear suspension.

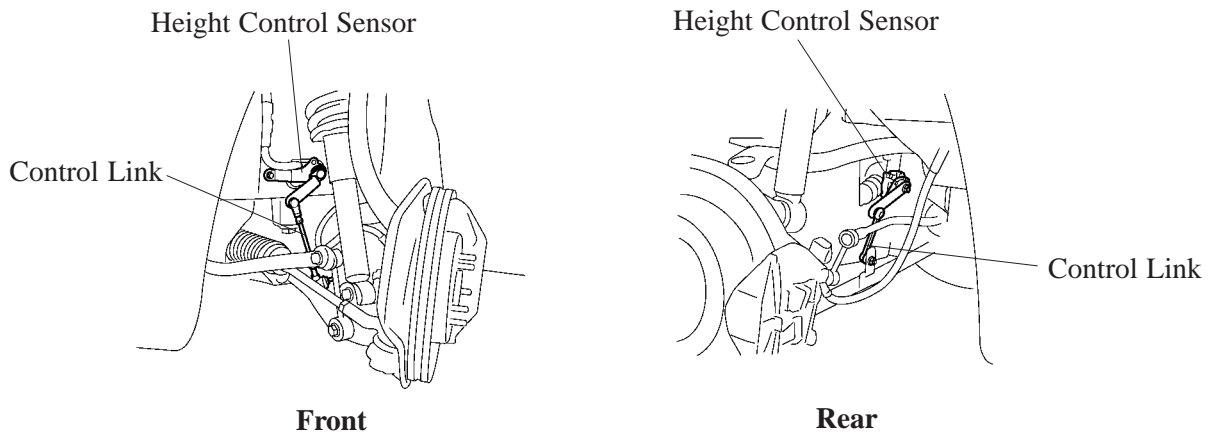

189BE116

BE

Skid Control ECU

The skid control ECU outputs the wheel speeds to the headlight beam level control ECU. The wheel speeds are calculated based on the signals which are received from the speed sensors which are part of the ABS.

Actuator

Based on the signals received from the headlight beam level control ECU, each actuator moves the reflector in the headlight to vary its beam. This actuator uses a step motor to precisely regulate the angle of the reflector.

4. Operation

While the vehicle is being driven, the vehicle posture changes constantly in accordance with the road surface conditions and other driving conditions. These postural changes of the vehicle are detected by the height control sensors, which are located in the front suspension and the rear suspension, in the form of the vertical movements (vehicle height variance) of the front and rear wheels. The detected signals are then transmitted to the headlight beam level control ECU. The ECU performs a calculation based on three values, the two signals that are transmitted by the sensors, and the wheel base, and determines the amount of variance in the vehicle's pitch angle.

To enable the actuators to move the reflectors in an effort to cancel out this amount of variance in the pitch angle that has been detected, the ECU transmits control signals to the actuators. In this manner, the ECU regulates the headlights to maintain a constant beam level regardless of any changes in the vehicle's posture. This system activates when the ignition switch is turned ON and the headlight control switch is turned ON.

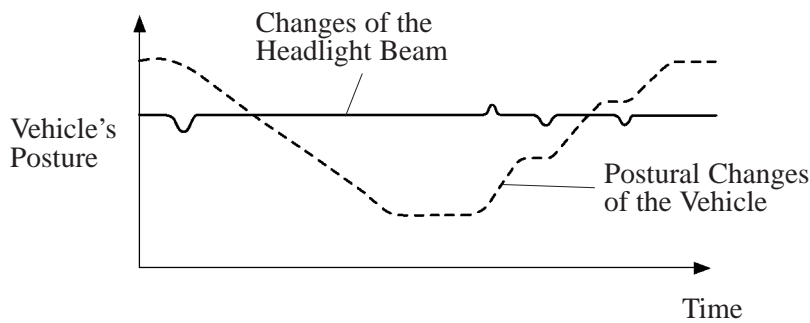

with Automatic Headlight Beam Level Control

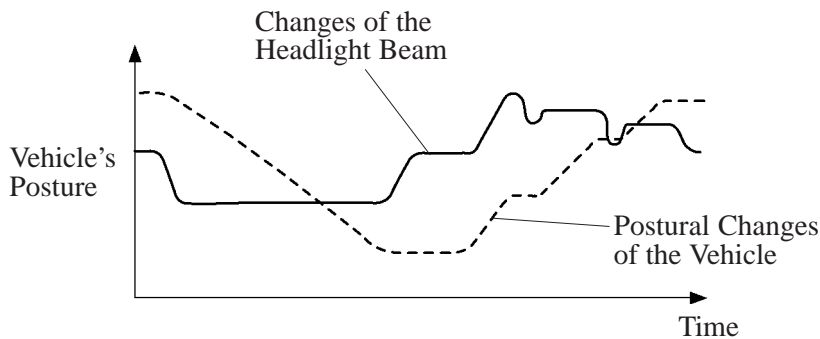

without Automatic Headlight Beam Level Control

5. Initial Set Control

When the ignition switch is turned ON and engine start, this function executes the initial set of the headlight beam level control ECU. Then, after sampling the wheel speeds, and the vehicle speed has been determined to be below 1.9 km/h (1.2 mph), the step motors are set to their initial setting.

6. Fail-Safe Function

The headlight beam level control ECU operates in the fail-safe mode if an abnormal condition such as those listed below has been detected, and displays a warning message on the multi-information display in the combination meter.

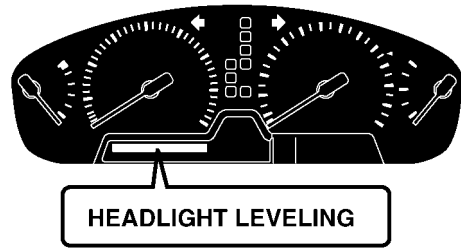

189BE63

Item	Abnormality Detection Condition	Description of Control
Actuator	Open or Short	Holds the beam at the position of the actuator when the abnormality has been detected.
Height Control Sensor	Signal Level Abnormality	Returns the beam to the actuator's initial set position if an abnormality has been detected higher than the initial set position.
		Holds the beam at the position of the actuator when an abnormality has been detected, if the abnormality has been detected lower than the initial set position.
Headlight Beam Level Control ECU	When an abnormal processing of the CPU has been detected.	Holds the beam at the position of the actuator when the abnormality has been detected.